



---

# PM1D System Software V1.4 Supplementary Manual

---



---

# Contents

---

<b>New functionality in system software V1.4</b> .....	<b>3</b>
<b>Digital gain for input channels / insert inputs</b> .....	<b>3</b>
Procedure .....	5
<b>Digital gain added to 2TR IN</b> .....	<b>6</b>
<b>BALANCE control for input channels / ST IN channels</b> .....	<b>6</b>
Procedure .....	8
<b>Temporary monaural setting for paired input channels / ST IN channels</b> .....	<b>9</b>
Front panel operating procedure .....	10
Screen operating procedure .....	11
Operation when monaural is selected .....	11
<b>M/S decoding</b> .....	<b>15</b>
Procedure .....	15
<b>Tracking Recall function</b> .....	<b>17</b>
Procedure .....	18

Thank you for purchasing the CS1D. This booklet explains the functionality that was added or changed in version 1.4 of the PM1D software.

## New functionality in system software V1.4

The following functionality and specifications have been added in version 1.4 of the PM1D system software.

- **Digital gain has been added to input channels/insert inputs**

Digital gain has been added to input channels and insert inputs, allowing you adjust the input sensitivity in the digital domain. Digital gain can be used in input channels and insert inputs to which an AD card, digital I/O card, 2TR IN, GEQ, or EFF are assigned.

Digital gain has been added to the six 2TR IN inputs. The sensitivity of the signal that is input to each 2TR IN can be adjusted in the digital domain, independently for L and R.

- **BALANCE has been added to PAN mode of the input channels**

The PAN parameter of an input channel can now be switched to a BALANCE parameter.

For adjacent odd-numbered/even-numbered input channels, you can switch the PAN parameter to a BALANCE parameter.

- **New capability to temporarily set paired input channels/ST IN channels to monaural**

The signals from paired input channels or ST IN channels can now be converted into monaural. As the monaural conversion method, you can select L-MONO (only the signal of the odd-numbered channel), R-MONO (only the signal of the even-numbered channel), or L,R-MONO (the signals of both channels mixed).

- **M/S decoding functionality**

“M/S decoding functionality” has been added, allowing a two-channel signal input from a MS mic to be converted into a L/R signal

- **Tracking Recall function**

The newly added “Tracking Recall” function lets you add a previously-specified offset value to the value of each fader when you recall a scene.

### Changes

- In the PAN/ROUTING function CH to MIX screen, the send level knob to the MATRIX bus is now displayed in gray to match the color of the encoder on the CS1D. This makes it easier to distinguish the MIX send level knob from the send level knob of the MATRIX/ST ROUTING function that sends the signal to the MATRIX bus.
- The rotational angle of the encoder-type knobs in the screen now matches the angle of the encoder knobs of the CS1D front panel. The index markings have changed in conjunction with this.
- Since V1.4 adds BALANCE to the PAN mode, the line in the screen that indicates the encoder knob position is now displayed in red for PAN (same as before) and white for BALANCE, to make it easier to distinguish the setting. In the MATRIX/ST function MATRIX/ST ROUTING screen as well, the encoder knob positions are displayed in red for PAN (same as before) and white for BALANCE.

## Digital gain for input channels/insert inputs

Digital gain has been added to input channels or insert inputs that are assigned to AD cards, digital I/O cards, 2TR IN, GEQ, or EFF. By using this, the input sensitivity can be adjusted in the digital domain even for input sources that do not have an analog head amp.

Since digital gain has been added, the input channel/insert input displays in the IN HA/INSERT, IN CH VIEW, INPUT UNIT, and MONITOR A/MONITOR B screens have changed as follows.

### ■ If an AD card (LMY4-AD) is assigned

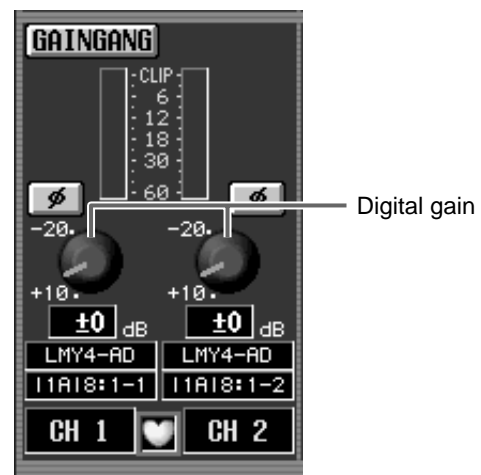

■ If a digital I/O card (MY card) is assigned

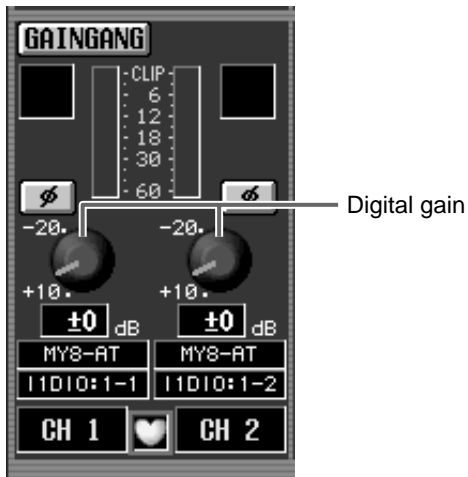

■ If a GEQ output is assigned

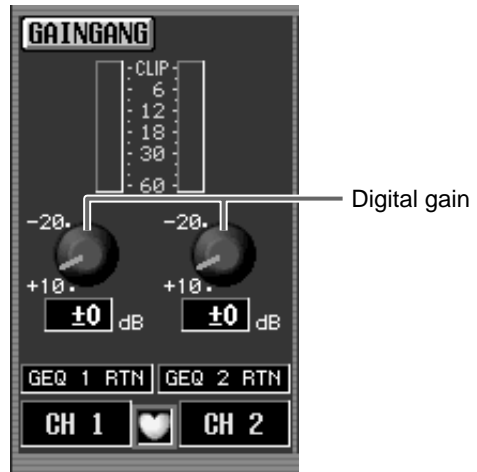

■ If 2TR IN is assigned

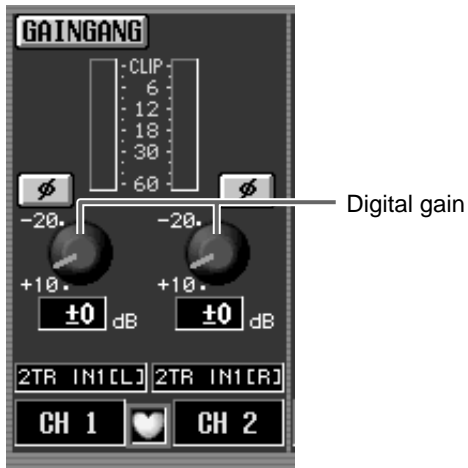

Digital gain can be used to adjust the input sensitivity in a range of +10 dB–20 dB (the knob will not turn any further to the right beyond –20 dB).

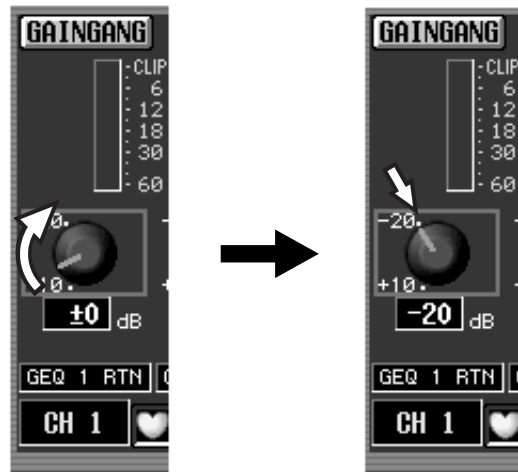

■ If the output of an effect return is assigned

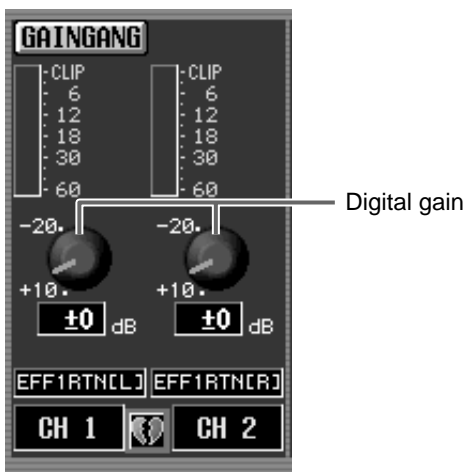

Only in the case of the digital gain for an input channel, you can also use the [GAIN] encoder of the CS1D's INPUT block to adjust the setting. In this case as well, the adjustable range for the input is +10 dB–20 dB (the knob will not turn any further to the right beyond –20 dB). Internally, the input sensitivity is adjusted in a gain range of –10 dB to +20 dB. If you want a digital source to be input at nominal level, set the GAIN knob in the screen to 0 dB.

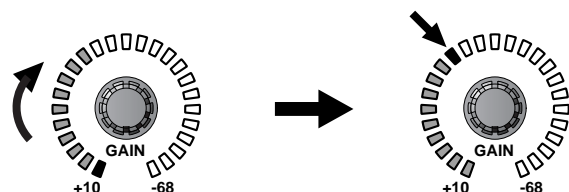

⚠ If a mic/line input card (LMY2-ML) is assigned to an input channel/insert input, the screen will show an analog gain knob (range: +10 dB–68 dB), just as in the previous software version.

⚠ If TB (talkback) is assigned to an input channel/insert input, the input level will be adjusted by the panel TALKBACK [LEVEL] volume, just as in the previous software version.

- ⚠ If 2TR IN is assigned to an input channel/insert input, the gain settings of the 2TR IN screen and the HA/INSERT screen will be linked. These settings cannot be set to different positions.
- ⚠ The digital gain of an input channel/insert input to which 2TR IN is assigned will not be saved in the scene memory.



Settings for the digital gain of an input card are saved in the unit library. Also, if the UNIT parameters of the corresponding channel are set to Recall Safe, the Recall Safe setting will also apply to the digital gain of the input card.

Settings for the digital gain of EFF/GEQ are saved in the scene memory. If the corresponding internal effect/GEQ is set to Recall Safe, the Recall Safe setting will also apply to the digital gain of the corresponding EFF/GEQ.

## Procedure

To adjust the digital gain of an input channel/insert input, use the following procedure.

1. In the INPUT PATCH screen (IN PATCH function), assign either an ML card or a source other than TB to the desired input channel/insert input.
2. Access the corresponding screen of the IN HA/INSERT function.

The following illustration shown an example of when an AD card (LMY4-AD) is assigned to the input channel/insert input.



3. Move the cursor to the GAIN knob in the screen, and turn the [DATA] encoder to adjust the digital gain.

In the case of an input channel, you can also use the [GAIN] encoder in the INPUT block of the CS1D, or the [GAIN] encoder in the SELECTED INPUT CHANNEL block.

4. If you want to link the gain setting of adjacent channels, click GAIN GANG switch to turn it on. If the GAIN GANG button is on, adjacent odd-numbered/even-numbered channels will have their gain setting linked (while maintaining the offset value).

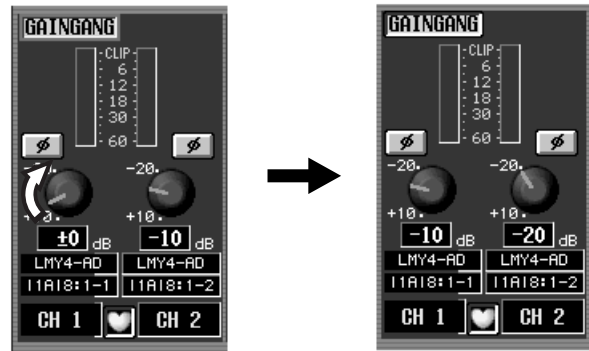

- ⚠ You can also use the GAIN GANG button to link analog gain and digital gain. However, when either the analog gain or the digital gain reaches the limit of its adjustment, neither channel will be adjustable beyond this point.

## Digital gain added to 2TR IN

Digital gain has been added to the six 2TR IN inputs, allowing you to adjust the input sensitivity in the digital domain. The sensitivity of the signal that is input to each 2TR IN can be adjusted independently for L and R.

In conjunction with this, the display in the 2TR IN screen (MON/CUE function) has changed as follows.



Digital gain is valid even if ANALOG is selected as the source for 2TR IN 1 or 2TR IN 2. In this case, the setting adjusts the sensitivity after AD conversion.



## BALANCE control for input channels/ST IN channels

As necessary, you can now control the BALANCE parameter instead of the PAN parameter for adjacent odd-numbered/even-numbered input channels or ST IN channels.

To do this, access the PAN/ROUTING function CH to MIX screen, and turn on the PAN MODE section BALANCE button.

### ■ STEREO bus

The PAN parameter that sends the signal to the STEREO bus will change to a BALANCE parameter. (A BAL knob will be displayed instead of a PAN knob in the PAN/ROUTING function CH to MIX screen.)

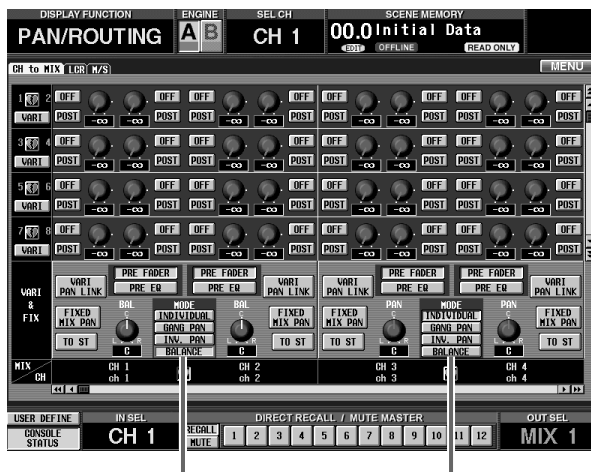

BALANCE button

When the BALANCE button is on, the signal flow from those two channels to the various buses will change as follows.

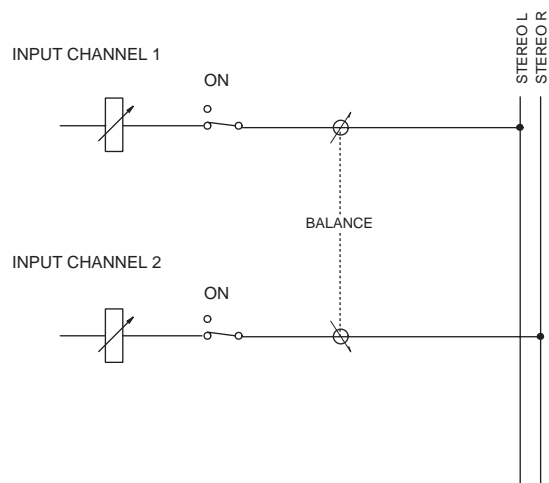

In this case, the signal of the odd-numbered input channel will be sent only to the L channel, and the signal of the even-numbered input channel will be sent only to the R channel. The BAL knob will adjust the volume of the two channels in tandem.

■ VARI type MIX bus

If a VARI type MIX bus is paired, the PAN parameter of the MIX bus will change to a BALANCE parameter. (A BAL knob will be displayed instead of a PAN knob in the PAN/ROUTING function CH to MIX screen.)



In this case, the signal of the odd-numbered input channel will be sent only to the odd-numbered MIX bus, and the signal of the even-numbered input channel will be sent only to the even-numbered MIX bus. The BAL knob will adjust the volume of the two signals in tandem.

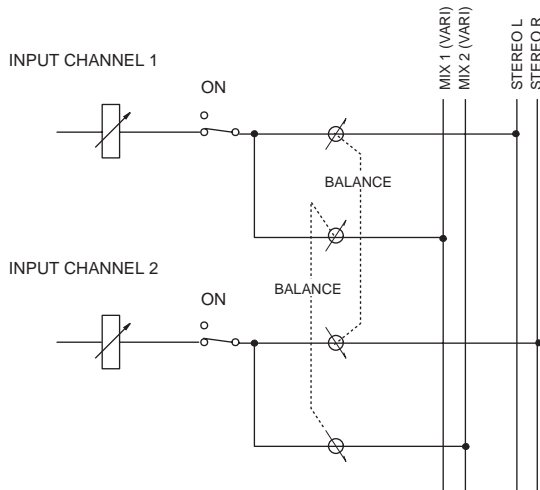

In addition, if the VARI PAN LINK button is on for either of these two channels, the MIX bus BAL knob will be linked with the STEREO bus BAL knob. If you operate either BAL knob of the STEREO bus or MIX bus, the remaining three BAL knobs will operate in tandem.

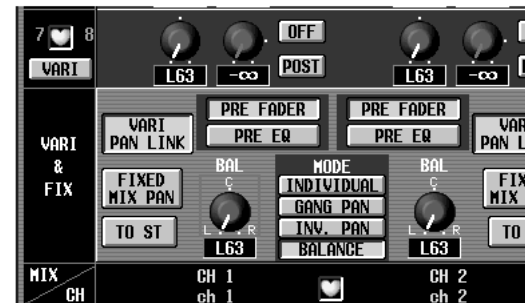
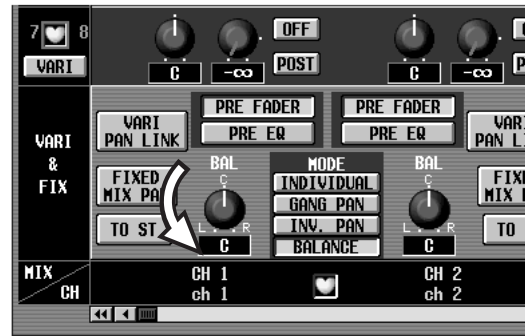

Even if the BALANCE button is on, the signal that is sent from those input channels to a VARI type MIX bus will not be affected unless the MIX bus is paired.

■ FIX type MIX bus

If the FIXED MIX PAN button is on for either of the two channels whose PAN MODE is set to BALANCE, the signal that flows from the corresponding input channel through the BALANCE parameter will be sent to the FIX type MIX bus. At this time, the signal of the odd-numbered input channel will be sent only to the odd-numbered MIX bus, and the signal of the even-numbered input channel will be sent only to the even-numbered MIX bus.

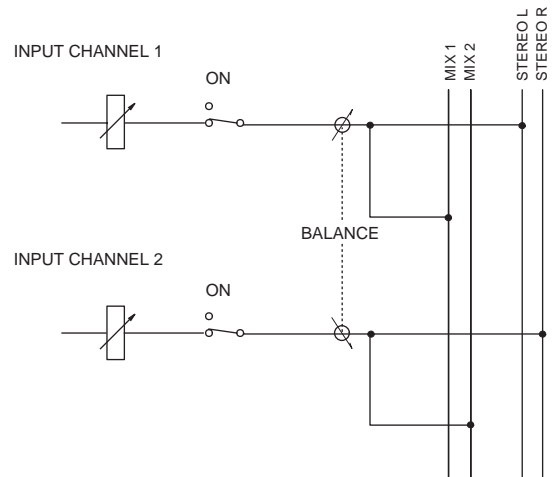



Even if the BALANCE button is on, the signal that is sent from those input channels to a FIX type MIX bus will not be affected if the FIXED MIX PAN button is turned off for both channels.

In addition, the operation will change as follows if the PAN MODE “BALANCE” button is on.

- Of the two channels for which the BALANCE button is turned on, if you save one of the channels in the channel library, the PAN MODE setting will be saved for the other channel even if it is not paired.
- When you recall data from the channel library, the PAN MODE or PAN value will not be recalled if the PAN MODE setting differs between the recall source and recall destination. However only if the recall destination is paired, the PAN MODE and PAN value will be recalled.
- When you copy channel data, the PAN MODE and PAN value will not be copied if the PAN MODE setting differs between the copy source and copy destination. However, the PAN MODE and PAN value will be copied only if the copy destination is paired.
- When recalling a channel library or copying a channel, if the channel that is not being recalled or copied is set to a PAN mode of BALANCE or if VARI PAN LINK is turned on, the MIX “BALANCE” value will be the same as the TO ST “BALANCE” in order to avoid inconsistencies between the TO ST value and MIX BALANCE value of the recalled or copied channels.

- When recalling scene data from a scene memory, and the PAN MODE setting of odd-numbered/even-numbered input channels does not match because one of the channels is set to Recall Safe, the PAN MODE or PAN values will not be recalled.
- For an input channel whose MIX send is set to Recall Safe, the PAN/BALANCE of the MIX send will also be subject to Recall Safe. For this reason if the PAN MODE settings of the recall source and recall destination do not match, it will not be possible to recall the PAN MODE or PAN/BALANCE values.
- In the case of an input channel in which the PAN MODE is BALANCE and the MIX send is set to Recall Safe, recalling a scene in which “PAN MODE=BALANCE, VARI PAN LINK=on” will cause the BALANCE value of the STEREO send to be recalled, but the BALANCE of the MIX send will be subject to Recall Safe. In this state, it is possible that BALANCE values of the STEREO send and MIX send will be inconsistent, so VARI PAN LINK will therefore be forcibly switched off. The PAN parameter fade function (INPUT CH PANNING, located in the SCENE function FADE TIME screen) can also be used when the BALANCE button is on. However, you must enable INPUT CH PANNING for both the odd-numbered and even-numbered channels.
- If the PAN MODE is switched from PAN to BALANCE (or vice versa) while the PAN parameter fade function is being executed, the PAN parameter fade function will be aborted for that channel.

## Procedure

Here's the procedure for operating the BALANCE parameter of input channels/ST IN channels.

1. Access the PAN/ROUTING function CH to MIX screen.
2. In the VARI & FIX area, turn on the TO ST button for adjacent odd-numbered/even-numbered channels or for a ST IN channel.
3. In the PAN MODE area, turn on the BALANCE button of the corresponding channels.

The PAN knobs in the screen (position indicator displayed in red) will change to BAL knobs (position indicator displayed in white), and will function as the balance parameter.



The BALANCE parameter is valid even if you do not enable pairing between the input channels.

4. Move the cursor to one of the BAL knobs, and turn the [DATA] encoder to adjust the value of the BALANCE parameter.

The BAL knobs of both channels will move in tandem.

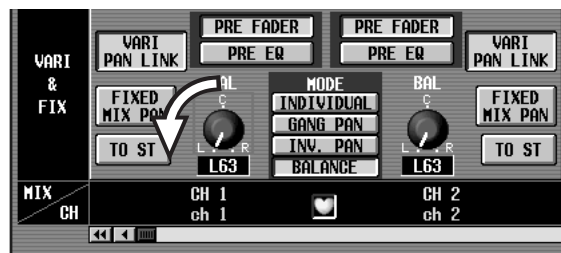

The BALANCE parameter can also be controlled from the INPUT block [PAN] encoder on the CS1D's front panel, or from the SELECTED INPUT CHANNEL block [PAN] encoder. In this case, the LEDs surrounding the [PAN] encoder will display as follows.

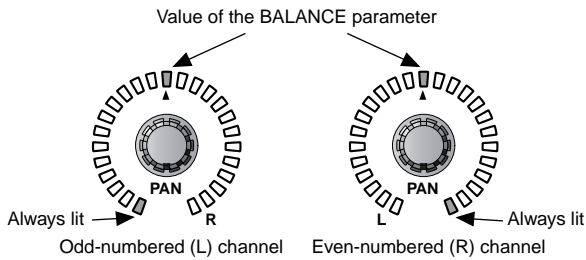

## Temporary monaural setting for paired input channels/ST IN channels

The input signal from paired input channels or ST IN channels can now be temporarily converted to monaural. You can select one of the following three modes.

### ■ Set to L-MONO

The channels will remain paired, but the signal will temporarily become a monaural signal containing only the odd-numbered channel.

The [ON] switch of the even-numbered channel will be forced off, and the PAN (BALANCE) of the odd-numbered channel will be set to the center.

#### When PAN MODE is other than BALANCE

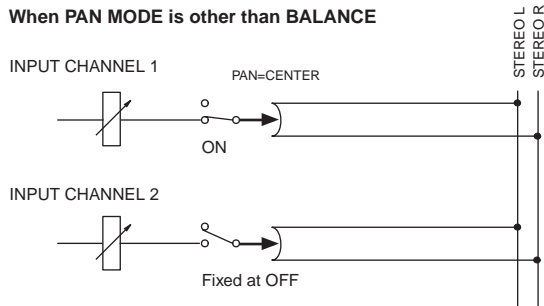

#### When PAN MODE is BALANCE

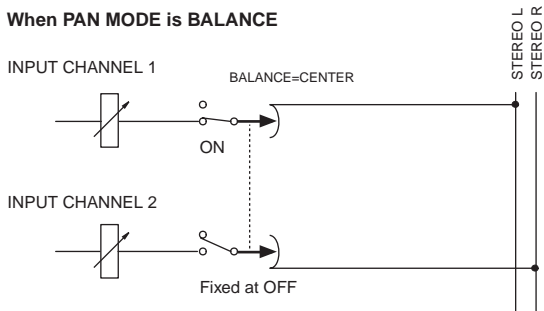

### ■ Set to R-MONO

The channels will remain paired, but the signal will temporarily become a monaural signal containing only the even-numbered channel.

The [ON] switch of the odd-numbered channel will be forced off, and the PAN (BALANCE) of the even-numbered channel will be set to the center.

#### When PAN MODE is other than BALANCE

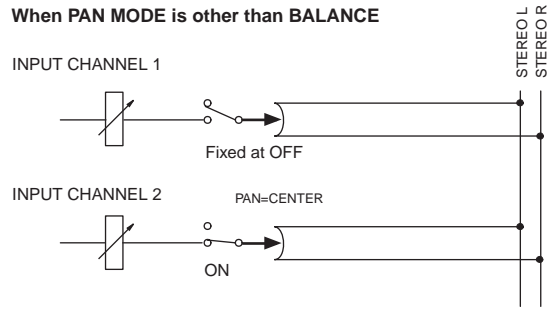

#### When PAN MODE is BALANCE

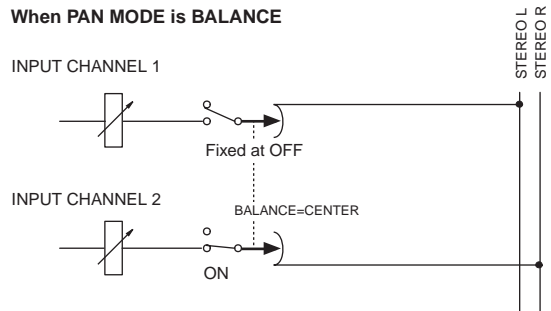

### ■ Set to LR-MONO

The channels will remain paired, but the signal will temporarily become a monaural signal containing both channels.

The PAN (BALANCE) of both channels will be set to the center.

#### When PAN MODE is other than BALANCE

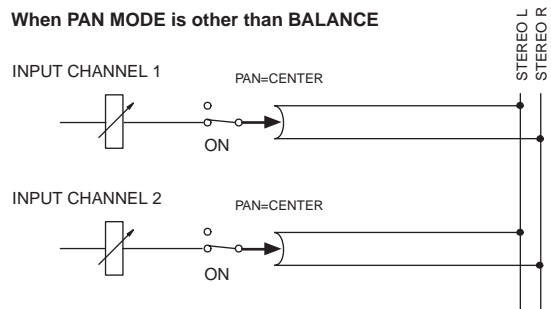

#### When PAN MODE is BALANCE

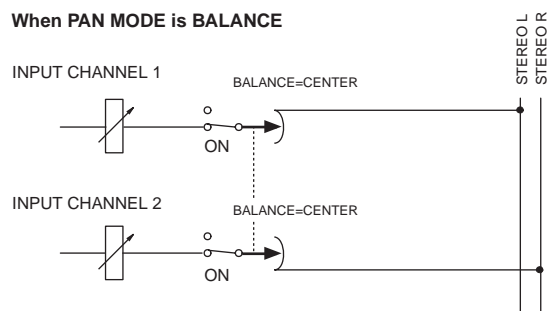

- ⚠ Even if L-MONO or R-MONO is selected, you can edit the parameters of the channel that was forced off. (However, the [ON] switch will be fixed at Off until you defeat the L-MONO or R-MONO setting, and cannot be changed.)
- ⚠ A new preference setting [L,R-MONO SELECT ON PANEL] has been added to the UTILITY function PREFERENCE screen, allowing you to switch to the LR-MONO setting from the front panel.

⚠ In previous versions of the system software, it was always possible to switch between PAIR and MONO from the front panel. However, a new preference setting [PROHIBIT PAIR CHANGE ON PANEL] has been added to the UTILITY function PREFERENCE screen, allowing you to enable/disable this function from being operated from the front panel.

## Front panel operating procedure

Here's how paired input channels/ST IN channels can be temporarily set to monaural from the front panel.

### 1. Access the UTILITY function PREFERENCE screen, and turn on the L,R-MONO SELECT ON PANEL button.

This allows the temporary change from stereo to monaural to be made from the front panel.



2. Specify pairing for any two adjacent odd-numbered/even-numbered input channels.
3. Use the front panel [SEL] switches and [SHIFT] switches to select one of the following three ways in which the channels will be temporarily set to monaural.
  - While holding down the [SHIFT] switch Press and hold the [SEL] switch of the odd-numbered (L) channel.....select L-MONO
  - While holding down the [SHIFT] switch Press and hold the [SEL] switch of the even-numbered (R) channel .....select R-MONO
  - While holding down the [SHIFT] switch Press and hold the [SEL] switches of both channels .....select LR-MONO

For the [SHIFT] switch described above, you may use any of the [SHIFT] switches in CHANNEL SELECT section of the SELECTED INPUT CHANNEL block or SELECTED OUT CHANNEL block, or the [SHIFT] switch of the data entry block.

You can use the same procedure as described above to change one temporary monaural setting to a different temporary monaural setting.

On the panel, the INPUT [NAME] indicator will blink alternately between the name of the channel that was set to temporary monaural and the name of the monaural mode. For a channel that is turned off, the INPUT [NAME] indicator will dimly display the channel name. The [NAME] indicator will also be displayed in the same way when these channels are recalled to a DCA fader. For details on operation when a monaural setting is selected, refer to page 11.

#### • Name indicator

##### For L-MONO:

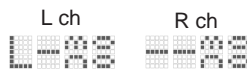

L ch: Alternately display and the channel name (the brightness depends on the on/off status)

R ch: Alternately display and the channel name (dimly)

##### For R-MONO:

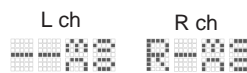

L ch: Alternately display and the channel name (dimly)

R ch: Alternately display and the channel name (the brightness depends on the on/off status)

##### For LR-MONO:

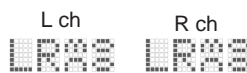

L ch: Alternately display and the channel name (the brightness depends on the on/off status)

R ch: Alternately display and the channel name (the brightness depends on the on/off status)

4. To defeat the temporary monaural setting, press the same combination of switches as you pressed in step 3.

The temporary monaural mode will be defeated, and the PAN (BALANCE) will return to the positions specified for the pair.

⚠ The MIX send PAN setting (or BALANCE setting) will be set to the same position as TO ST.



In order to prevent accidents, it is possible to prohibit the operator from using the [SEL] switches to set/cancel pairing. To prohibit this, go to the PREFERENCE screen and turn the PROHIBIT PAIR CHANGE ON PANEL button on.

### Screen operating procedure

Here's how paired input channels/ST IN channels can be temporarily set to monaural from within the screen.

1. Specify pairing for the desired adjacent odd-numbered/even-numbered input channels.
2. Access a screen (such as the IN HA/INSERT function) that shows the heart symbols, and for the channels that you want to temporarily set to monaural, click the pair/stereo indicator heart symbol while you hold down the [SHIFT] switch of the data entry block. Alternatively, move the cursor to the heart symbol, then hold down the [SHIFT] switch and press the [ENTER] switch.

The following popup window will appear.





⚠ Only the [SHIFT] switch of the data entry block can be used to select the temporary monaural setting from the screen.



If you click without holding down the [SHIFT] switch, you will switch between conventional pairing/monaural.

3. Move the cursor to the desired button, and press the [ENTER] key. The setting will be made the instant you press the [ENTER] key.

Each button has the following meaning.

-  .....Specify L-MONO
-  .....Specify R-MONO
-  .....Specify LR-MONO

If none of the above three buttons are on, the channels will be paired.

When you make the monaural setting, the heart symbol will change as follows.

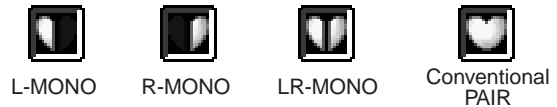

The same type of popup window will appear if you hold down the [SHIFT] switch and press the [ENTER] switch on the heart symbol of an unpaired channel. However, it will not be possible to select L-MONO/R-MONO/LR-MONO.

4. To cancel the temporary monaural setting, hold down the [SHIFT] switch and click the above heart symbol once again, press the same button as you selected in step 3, and press OK.

The monaural setting will be cancelled, and the PAN (BALANCE) will return to its position at the time it was paired.



By moving the cursor to a different button and pressing the [ENTER] switch, you can move to a different channel for which to make temporary monaural settings.

Also, pairing can be defeated in the usual way even if channels are temporarily set to monaural.

### Operation when monaural is selected

The following points describe details of operation when the L-MONO, R-MONO, or LR-MONO settings are selected.

- Input channels that are temporarily set to monaural can be changed to L-MONO, R-MONO, LR-MONO, pairing defeated, or paired settings. However, the input signal of a ST IN channel cannot be set to monaural (pairing defeated).

- When you return to a paired state after selecting temporary monaural, the PAN setting and PAN mode will return to the PAN/BALANCE position that had been in effect when pairing was specified.
- When the signal of an input channel is sent to a MIX bus, any temporary monaural mode L-MONO, R-MONO, or LR-MONO will operate in the same way as normal monaural (pairing defeated) mode.

However, CUE on/off and Recall Safe that are not set independently for L and R in a ST IN channel will be linked or non-linked as a pair, even if LR-MONO is selected.

For a ST IN channel, these parameters will always be linked regardless of the temporary monaural setting.

- If the STEREO bus send PAN mode is set to BALANCE for an input channel, the MIX bus is paired, and the MIX bus type is VARI, the MIX bus PAN mode will also be BALANCE.  
(The BALANCE value can be set individually.)  
However if the channel is changed from a temporary monaural setting to Pair, the MIX bus PAN position will return to the same position as the STEREO bus PAN/BALANCE that was in effect when the channel was paired.
- In the front panel SELECTED INPUT CHANNEL block, the CHANNEL SELECT indicators MONO and PAIR will both light if any of the temporary monaural modes L-MONO/R-MONO/LR-MONO are selected. Other displays are the same as in software version 1.3.
- Copying between paired channels that are temporarily set to monaural can be performed between paired channels. Copying to channels that are temporarily set to monaural can be performed only from a L-MONO/R-MONO/LR-MONO/PAIR channel. It is not possible to copy from a temporarily monaural channel to a monaural channel.
- For a temporarily monaural channel, the display in the CH VIEW screen that is accessed by the front panel LCD FUNCTION ACCESS [CH VIEW] switch will be the same as the MONO display.
- Channel libraries can be stored or recalled in monaural if paired channels are set to any temporary monaural setting L-MONO, R-MONO, or LR-MONO. Libraries cannot be recalled or stored as a pair.
- CUE will function according to the pairing on/off setting, and will not be affected by this temporary monaural setting. Just as in software version 1.3, CUE will operate in the same way as CUE for paired channels, regardless of this temporary monaural setting. CUE on/off is linked for L/R channels, and in the case of PFL, the L channel signal will be sent to the L side of the CUE bus, and the R channel signal to the R side of the CUE bus (i.e., CUE in stereo). In the case of AFL, operation will be the same as CUE for paired channels. If the L-MONO or R-MONO temporary monaural setting is selected, turning off either channel will cause that channel to no longer be sent to the CUE bus.

- Recall Safe will operate according to the pair on/off setting, regardless of the temporary monaural setting. If Recall Safe is specified for only one of the two channels, and you recall a scene for channels that are set to monaural, a warning message will be displayed to inform you that monaural will be cancelled even if the channel contains Recall Safe parameters. Then pairing will be cancelled. Only the channel that is not set to Recall Safe will be recalled. In the case of L-MONO, recalling the R channel will cause that channel to be recalled in an Off state. In the case of LR-MONO, recalling the L channel will cause that channel to be recalled in an Off state.
- If you recall channel library no.00, these temporary monaural settings will be the same as for unpaired channels. In other words, the PAN mode will remain as it was, and the PAN/BALANCE will be set to the center. For paired channels, the PAN mode will be forced to INDIVIDUAL, and operation will be the same as in software version 1.30.
- The fade time will operate according to the pair on/off setting, without being affected by this temporary monaural setting. When paired, the fade time of the two channels will be linked.
- Insert on/off, insert point, and direct point can now be set separately for L/R even if one of the temporary monaural modes L-MONO/R-MONO/LR-MONO are selected. (This setting is stored in the scene memory.)
- If a channel library is recalled to the channel that is forced off by a L-MONO or R-MONO setting (i.e., the R channel in the case of L-MONO, or the L channel in the case of R-MONO), the recalled channel will be forced off.
- The KEY IN link for GATE or COMP will not be changed by any of these temporary monaural settings. LINK will be turned on only if monaural is changed to pair. LINK will not be turned off when the setting is changed from pair to link.

If PAN is changed:

		PAN* <sup>1</sup> → BALANCE	BALANCE → PAN* <sup>1</sup>
MONO mode		<ul style="list-style-type: none"> <li>BALANCE will be CENTER.*<sup>2</sup></li> <li>The PAN that is sent to a MIX bus that is both paired and VARI-type will change to BALANCE, and set to CENTER.</li> </ul>	<ul style="list-style-type: none"> <li>The L channel PAN will be set to far left, and the R channel PAN will be set to far right.*<sup>2</sup></li> <li>The BALANCE that is sent to a paired VARI-type MIX bus will change to PAN, and panned to left and right as above.</li> </ul>
PAIR mode	PAIR		
	R-MONO		

\*1: PAN refers to any of the pan modes INDIVIDUAL PAN, GANG PAN, or INVERTED GANG PAN.

\*2: This is the operation that occurs when the PAN MODE is changed in the screen. If it is changed by a scene recall, it will follow the stored PAN/BALANCE setting.

If PAIR is changed:

		Cancel pairing → Specify pairing	Paired Pairing defeated
PAN* <sup>1</sup>		<ul style="list-style-type: none"> <li>PAN setting remains as is.</li> </ul>	
BALANCE			

\*1: PAN refers to any of the pan modes INDIVIDUAL PAN, GANG PAN, or INVERTED GANG PAN.

		Paired → L-MONO	L-MONO → Paired
PAN* <sup>1</sup>		<ul style="list-style-type: none"> <li>The PAN value of the L/R channels and the PAN MODE setting will be temporarily preserved.</li> <li>The L/R channel PAN will be CENTER.*<sup>2</sup></li> <li>PAN to a paired VARI-type MIX bus will also be set to CENTER.</li> <li>The R channel ON/OFF will be turned OFF, and cannot be turned ON.</li> </ul>	<ul style="list-style-type: none"> <li>The PAN/BALANCE value of the L/R channels and the PAN MODE will return to the settings that were in effect when the channels were paired.*<sup>2</sup></li> <li>PAN to a paired VARI-type MIX bus will change to PAN or BALANCE, and will be set to the same value as the temporarily preserved PAN value for TO ST.</li> <li>R-channel parameters other than PAN will be set identically to the L channel.*<sup>3</sup></li> </ul>
BALANCE		<ul style="list-style-type: none"> <li>The BALANCE value of the L/R channels and the PAN MODE setting will be temporarily preserved.</li> <li>The L/R channel PAN will be CENTER.*<sup>2</sup></li> <li>BALANCE to a paired VARI-type MIX bus will change to PAN, and set to CENTER.</li> <li>The R channel ON/OFF will be turned OFF. (Cannot be turned ON.)</li> <li>PAN MODE will be set to INDIVIDUAL PAN.</li> </ul>	

\*1: PAN refers to any of the pan modes INDIVIDUAL PAN, GANG PAN, or INVERTED GANG PAN.

\*2: This is the operation that will occur when pairing settings are changed in the screen or panel. If pairing settings were changed as a result of a scene recall, the stored PAN/BALANCE status will be followed.

\*3: "Parameters" refers to parameters that are linked when channels are paired.

		Paired → R-MONO	R-MONO → Paired
PAN* <sup>1</sup>		<ul style="list-style-type: none"> <li>The PAN value of the L/R channels and the PAN MODE setting will be temporarily preserved.</li> <li>The L/R channel PAN will be CENTER.*<sup>2</sup></li> <li>PAN to a paired VARI-type MIX bus will also be set to CENTER.</li> <li>The L channel ON/OFF will be turned OFF, and cannot be turned ON.</li> </ul>	<ul style="list-style-type: none"> <li>The PAN/BALANCE value of the L/R channels and the PAN MODE will return to the settings that were in effect when the channels were paired.*<sup>2</sup></li> <li>PAN to a paired VARI-type MIX bus will change to PAN or BALANCE, and will be set to the same value as the temporarily preserved PAN value for TO ST.</li> <li>L-channel parameters other than PAN will be set identically to the R channel.*<sup>3</sup></li> </ul>
BALANCE		<ul style="list-style-type: none"> <li>The BALANCE value of the L/R channels and the PAN MODE setting will be temporarily preserved.</li> <li>The L/R channel PAN will be CENTER.*<sup>2</sup></li> <li>BALANCE to a paired VARI-type MIX bus will change to PAN, and set to CENTER.</li> <li>The L channel ON/OFF will be turned OFF. (Cannot be turned ON.)</li> <li>PAN MODE will be set to INDIVIDUAL PAN.</li> </ul>	

\*1: PAN refers to any of the pan modes INDIVIDUAL PAN, GANG PAN, or INVERTED GANG PAN.

\*2: This is the operation that will occur when pairing settings are changed in the screen or panel. If pairing settings were changed as a result of a scene recall, the stored PAN/BALANCE status will be followed.

\*3: "Parameters" refers to parameters that are linked when channels are paired.

	Paired → LR-MONO	LR-MONO → Paired
PAN *1	<ul style="list-style-type: none"> <li>The PAN value of the L/R channels and the PAN MODE setting will be temporarily preserved.</li> <li>The L/R channel PAN will be CENTER.*2</li> <li>PAN to a paired VARI-type MIX bus will also be set to CENTER.</li> </ul>	<ul style="list-style-type: none"> <li>The PAN/BALANCE value of the L/R channels and the PAN MODE will return to the settings that were in effect when the channels were paired.*2</li> <li>PAN to a paired VARI-type MIX bus will change to PAN or BALANCE, and will be set to the same value as the temporarily preserved PAN value for TO ST.</li> <li>R-channel parameters other than PAN will be set identically to the L channel.*3</li> </ul>
BALANCE	<ul style="list-style-type: none"> <li>The BALANCE value of the L/R channels and the PAN MODE setting will be temporarily preserved.</li> <li>The L/R channel PAN will be CENTER.*2</li> <li>BALANCE to a paired VARI-type MIX bus will change to PAN, and set to CENTER.</li> <li>PAN MODE will be set to INDIVIDUAL PAN.</li> </ul>	

\*1: PAN refers to any of the pan modes INDIVIDUAL PAN, GANG PAN, or INVERTED GANG PAN.

\*2: This is the operation that will occur when pairing settings are changed in the screen or panel. If pairing settings were changed as a result of a scene recall, the stored PAN/BALANCE status will be followed.

\*3: "Parameters" refers to parameters that are linked when channels are paired.

	L-MONO → Pairing defeated R-MONO → Pairing defeated LR-MONO → Pairing defeated	Pairing defeated → L-MONO Pairing defeated → R-MONO Pairing defeated → LR-MONO
PAN *1	<ul style="list-style-type: none"> <li>The L/R channel PAN setting and PAN MODE will not change.</li> <li>PAN to a paired VARI-type MIX bus will not change.</li> </ul>	<ul style="list-style-type: none"> <li>These operations are invalid.</li> </ul>
BALANCE	<ul style="list-style-type: none"> <li>The BALANCE setting of the L/R channels and the PAN MODE setting will not change.</li> <li>The PAN setting to a paired VARI-type MIX bus will not change.</li> </ul>	

\*1: PAN refers to any of the pan modes INDIVIDUAL PAN, GANG PAN, or INVERTED GANG PAN.

	L-MONO → R-MONO	R-MONO → L-MONO
PAN *1	<ul style="list-style-type: none"> <li>The PAN value of the L/R channels and the PAN MODE setting will not change.</li> <li>PAN to a paired VARI-type MIX bus will also remain unchanged.</li> <li>The R channel ON/OFF will be set to the same setting as the L channel, and the L channel ON/OFF setting will be turned OFF.</li> </ul>	<ul style="list-style-type: none"> <li>The PAN value of the L/R channels and the PAN MODE setting will not change.</li> <li>PAN to a paired VARI-type MIX bus will also remain unchanged.</li> <li>The L channel ON/OFF will be set to the same setting as the R channel, and the R channel ON/OFF setting will be turned OFF.</li> </ul>
BALANCE	<ul style="list-style-type: none"> <li>The BALANCE value of the L/R channels and the PAN MODE setting will not change.</li> <li>BALANCE to a paired VARI-type MIX bus will also remain unchanged.</li> <li>The R channel ON/OFF will be set to the same setting as the L channel, and the L channel ON/OFF setting will be turned OFF.</li> </ul>	<ul style="list-style-type: none"> <li>The BALANCE value of the L/R channels and the PAN MODE setting will not change.</li> <li>BALANCE to a paired VARI-type MIX bus will also remain unchanged.</li> <li>The L channel ON/OFF will be set to the same setting as the R channel, and the R channel ON/OFF setting will be turned OFF.</li> </ul>

\*1: PAN refers to any of the pan modes INDIVIDUAL PAN, GANG PAN, or INVERTED GANG PAN.

	L-MONO → LR-MONO	R-MONO → LR-MONO
PAN *1	<ul style="list-style-type: none"> <li>The PAN value of the L/R channels and the PAN MODE setting will not change.</li> <li>PAN to a paired VARI-type MIX bus will also remain unchanged.</li> <li>The R channel ON/OFF will be set to the same setting as the L channel, and the L channel ON/OFF setting will not change.</li> </ul>	<ul style="list-style-type: none"> <li>The PAN value of the L/R channels and the PAN MODE setting will not change.</li> <li>PAN to a paired VARI-type MIX bus will also remain unchanged.</li> <li>The L channel ON/OFF will be set to the same setting as the R channel, and the R channel ON/OFF setting will not change.</li> </ul>
BALANCE	<ul style="list-style-type: none"> <li>The PAN (BALANCE) value of the L/R channels and the PAN MODE setting will not change.</li> <li>PAN to a paired VARI-type MIX bus will also remain unchanged.</li> <li>The R channel ON/OFF will be set to the same setting as the L channel, and the L channel ON/OFF setting will not change.</li> </ul>	<ul style="list-style-type: none"> <li>The PAN (BALANCE) value of the L/R channels and the PAN MODE setting will not change.</li> <li>PAN to a paired VARI-type MIX bus will also remain unchanged.</li> <li>The L channel ON/OFF will be set to the same setting as the R channel, and the R channel ON/OFF setting will not change.</li> </ul>

\*1: PAN refers to any of the pan modes INDIVIDUAL PAN, GANG PAN, or INVERTED GANG PAN.

	LR-MONO → L-MONO	LR-MONO → R-MONO
PAN **1	<ul style="list-style-type: none"> <li>The PAN value of the L/R channels and the PAN MODE setting will not change.</li> <li>PAN to a paired VARI-type MIX bus will also remain unchanged.</li> <li>The R channel ON/OFF will be turned OFF, and the L channel ON/OFF setting will not change.</li> </ul>	<ul style="list-style-type: none"> <li>The PAN value of the L/R channels and the PAN MODE setting will not change.</li> <li>PAN to a paired VARI-type MIX bus will also remain unchanged.</li> <li>The L channel ON/OFF will be turned OFF, and the R channel ON/OFF setting will not change.</li> </ul>
BALANCE	<ul style="list-style-type: none"> <li>The PAN (BALANCE) value of the L/R channels and the PAN MODE setting will not change.</li> <li>PAN to a paired VARI-type MIX bus will also remain unchanged.</li> <li>The R channel ON/OFF will be turned OFF, and the L channel ON/OFF setting will not change.</li> </ul>	<ul style="list-style-type: none"> <li>The PAN (BALANCE) value of the L/R channels and the PAN MODE setting will not change.</li> <li>BALANCE to a paired VARI-type MIX bus will also remain unchanged.</li> <li>The L channel ON/OFF will be turned OFF, and the R channel ON/OFF setting will not change.</li> </ul>

\*1: PAN refers to any of the pan modes INDIVIDUAL PAN, GANG PAN, or INVERTED GANG PAN.

## M/S decoding

M/S decoding functionality is now provided, allowing a two-channel signal input from a MS mic through adjacent odd-numbered/even-numbered input channels to be converted into L/R signals.

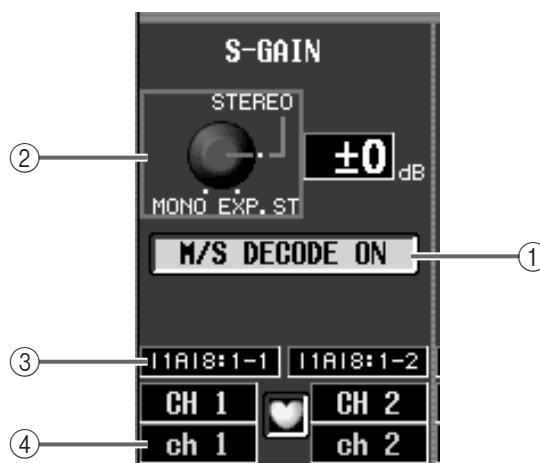
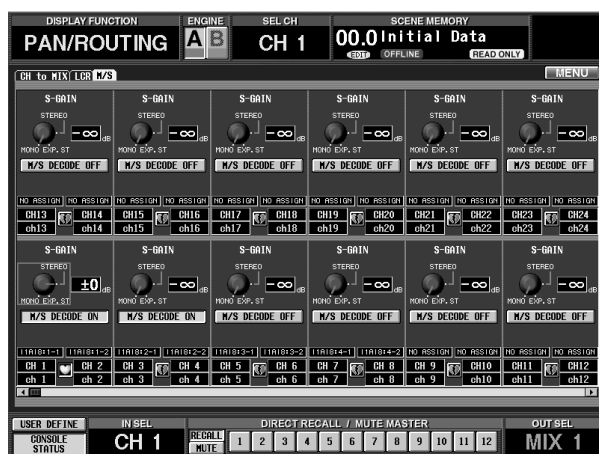

### ① M/S DECODE ON/OFF button

This switches the M/S decoding function on/off, in groups of two adjacent odd-numbered/even-numbered channels (or a stereo input channel). The M/S decode function can be turned on even for channels that are not specified as a stereo pair.

### ② S-GAIN knob

This sets the level difference of the S mic, relative to the level of the M mic. The current value is shown in the numerical box at the right.

At the MONO position, the S mic level will be -infinity. At the EXP.ST position, the S mic level will be +10 dB.

At the STEREO position, the levels of the M mic and S mic will be the same.

### ③ Unit type/ID number/channel number

These indicate the type of input assigned to the corresponding channel, the ID number, and the channel number of the input jack.

### ④ Channel/Pair settings

These indicate the number of the currently displayed input channel and the pairing status. You can also click the heart symbol in this screen to set or defeat pairing.

## Procedure

Here's how to decode an MS mic input signal.

### 1. Connect the MS mics to two channels of an input unit, and assign them to two adjacent odd-numbered/even-numbered channels.

Assign the M mic to the odd-numbered (L) channel, and the S mic to the even-numbered (R) channel.

### 2. If necessary, specify the above two channels as a pair.

⚠ MS decoding can be used even if the input channels are not paired.

3. Access the PAN/ROUTING function M/S screen.

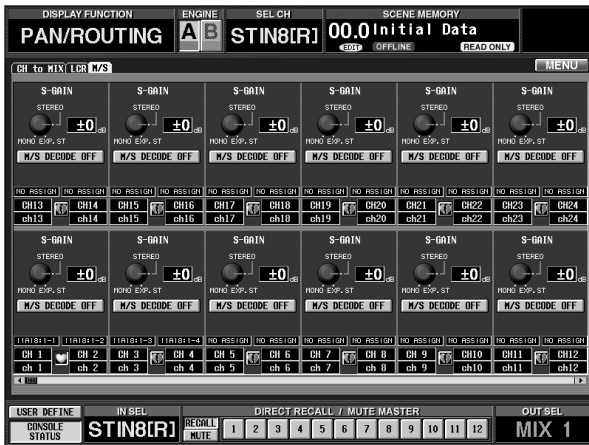

4. Click the M/S DECODE ON/OFF button for the corresponding two channels, to turn the button on.



With this setting, the odd-numbered (L) channel will input the (M+S) signal, and the even-numbered (R) channel will input the (M–S) signal (the M signal summed with the inverted-phase S signal).

⚠ Even if only one signal (the M signal or S signal) is patched to an input channel, turning M/S DECODE on will send the signal to both channels.

5. Move the cursor to the S-GAIN knob, and turn the [DATA] encoder to adjust the level of the S mic relative to the M mic.

At the MONO position, S = –infinity. At the STEREO position, M = S. At the EXP.ST position, S = +10 dB.

⚠ M/S decoding is performed immediately after DE-EMPHASIS and immediately before ATT. (attenuator).

For this reason, please note that when M/S decoding is on, the following meters will show the signal level before M/S decoding.

- The input unit meter displayed in the HA/INSERT function screen
- The screen/panel meters when the METER function METERING POINT setting is set to PRE ATT.

- The input unit meter displayed in the INPUT UNIT screen (SYS/W.CLOCK function)

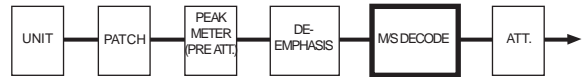

⚠ A headroom margin of approximately 18 dB is maintained before M/S decoding. If the signal clips while you are using M/S decoding, you can use the attenuator to lower the level and input an unclipped signal if the clipping is below the headroom margin.

⚠ Since M/S decoding is a special function, it cannot be copied between channels or saved in a channel library. Also, the RESET BOTH button in the CHANNEL PAIRING popup window will not be valid.

## Tracking Recall function

A “Tracking Recall” function has been added, which lets you add a pre-specified offset value to the value of each fader when a scene is recalled.

You can use this Tracking Recall function when (for example) you want to make fine adjustments to the faders of specific channels, so that the specified offset value will automatically be added each time a scene is recalled.

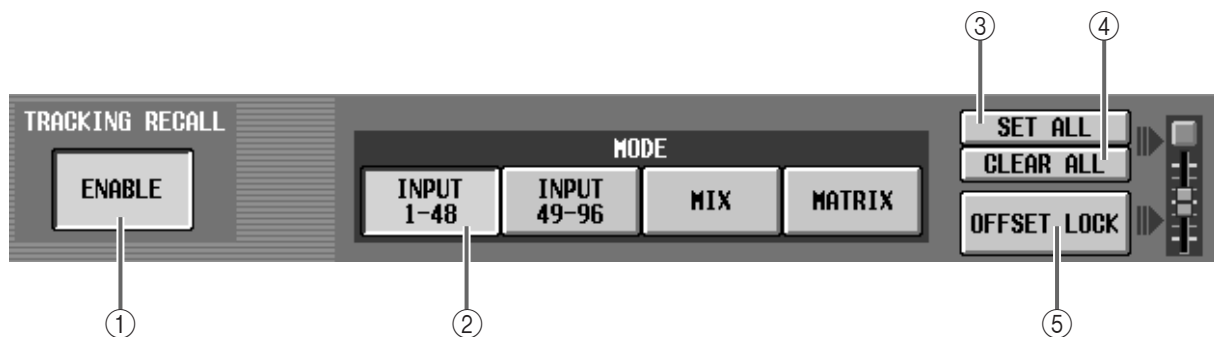

### ① TRACKING RECALL button

This button switches Tracking Recall on/off. Tracking Recall is on when ENABLE is displayed (the button will turn green).

### ② MODE buttons

These buttons select the group of channels (input channels 1–48, input channels 49–96, MIX channels, MATRIX channels) for which you will make Tracking Recall settings. The channels displayed in the screen will change according to the button you select. (However, STEREO A/B and DCA will always be displayed regardless of the MODE button that is selected.)

### ③ SET ALL button

When this button is turned on, the ON buttons (6) of all channels (including channels that are not currently displayed in the screen) will be turned on, and tracking will be specified for all channels.

### ④ CLEAR ALL button

When this button is turned on, the ON buttons (6) of all channels (including channels that are not currently displayed in the screen) will be turned off, and tracking will be defeated for all channels.

### ⑤ OFFSET LOCK button

When this button is turned on, the sliders of all channels (including channels that are not currently displayed in the screen) will be displayed in gray, and it will not be possible to change the offset value further.

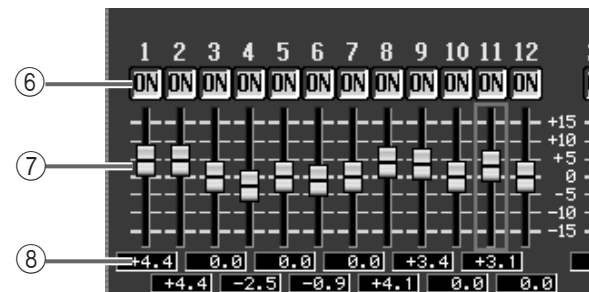

### ⑥ ON buttons

These buttons enable/defeat tracking for each channel.

If the TRACKING RECALL button is set to ENABLE, tracking will be enabled for channels for which this button is displayed as ON.

### ⑦ Faders

These faders specify an offset value in the range of +/–15 dB that will be applied to each channel when tracking is enabled.

### ⑧ Offset values

These indicate the offset value for each channel.

## Procedure

Here's how to use the Tracking Recall function.

**1. Access the SCENE function TRACKING RECALL screen.**

In the TRACKING RECALL screen, tracking can be turned on/off for each channel, and you can specify the offset value that will be applied to each channel for which Tracking Recall is on.

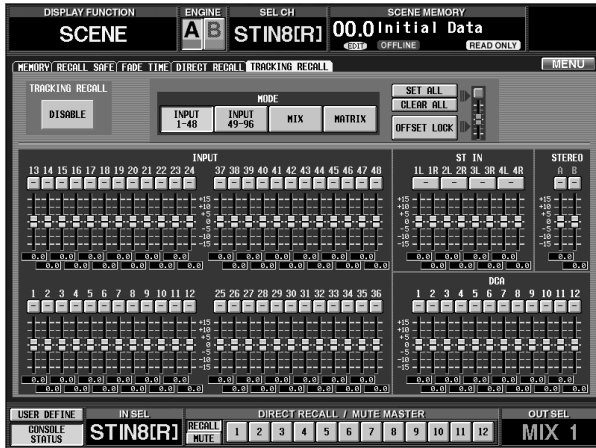

**2. Press a MODE button (INPUT 1-48, INPUT 49-96, MIX, MATRIX) so that the desired channels appear in the screen.**

**3. Click the ON button of the channels for which you want to use tracking.**

At this point, the fader position of a channel that you have turned on by clicking will be memorized as the reference position. Thus, the offset value will be set to 0.



By clicking the SET ALL or CLEAR ALL buttons in the upper right of the screen, you can enable/disable tracking for all channels (including channels that are not currently displayed in the screen).

**4. Raise or lower the faders of channels for which tracking is turned on, to specify their offset value.**

Move the front panel faders from the reference positions that were memorized in step 3. The distance of this movement will be set as the offset value. The offset value can also be specified by moving the sliders in the screen. However if you use the sliders in the screen to specify the offset, the front panel faders will not change position.

The offset value can be specified in a range of -15-0-+15 dB. After you have specified the desired offset values, you can turn on the OFFSET LOCK button in the screen to make the sliders turn gray, disabling any further change in the offset values.

**!** If you move the front panel faders while OFFSET LOCK is on, the offset value will not be re-set even if you then defeat OFFSET LOCK. This is because

you may wish to defeat OFFSET LOCK in order to make manual changes in the screen. If you move the faders after defeating OFFSET LOCK, the offset will be calculated from the reference position of step 3 before tracking is recalled (an offset value of 0 dB), and set accordingly.

**5. In the upper left of the screen, click the TRACKING RECALL button to switch it to ENABLE.**

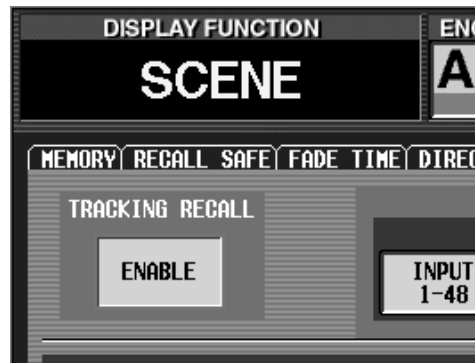

In this example, the Tracking function was enabled in step 5. However, the TRACKING RECALL button can be operated at any time.

**6. Recall the desired scene.**

The offset values you specified in step 4 will be added to the value of each fader in the recalled scene.



The faders of channels that are set to Recall Safe will not change even if Tracking Recall is turned on. Nor will the offset value change.



If the ENABLE button of the TRACKING RECALL area is off, the specified offset value will not be added to the recalled faders. The offset value will return to zero when recall occurs unless the OFFSET LOCK button is on. If you want to set a specific scene to the reference position (offset 0), you should turn off the ENABLE button of the TRACKING RECALL area and also turn off the OFFSET LOCK button before recalling the scene.

If the ENABLE button of the TRACKING RECALL area is on, and you recall a scene not set to Recall Safe, the fader values that were stored in the scene will be offset by the specified value for each channel for which the Tracking function is on, and the faders will move to the closest possible location for the calculated value.



In the case of channels that are newly paired due to a recall, offset will be considered to be off unless the ON buttons of those two channels are both turned on, and the offset value will not be added. If the ON buttons of both channels are on, then the offset value will be the average of the two values.

- If the OFFSET LOCK button is off for a channel that is recalled from the channel library, the offset value will be 0.

- If the OFFSET LOCK button is off for a channel that is channel-copied, the offset value will also be copied.
-  When the power of the CS1D is turned off, and then on once again, the ENABLE button of the TRACKING RECALL area will be turned off for the sake of safety, disabling the Tracking Recall function.

