



DME-N Network Driver Installation Guide for DSP5D

ATTENTION

SOFTWARE LICENSE AGREEMENT

PLEASE READ THIS SOFTWARE LICENSE AGREEMENT ("AGREEMENT") CAREFULLY BEFORE USING THIS SOFTWARE. YOU ARE ONLY PERMITTED TO USE THIS SOFTWARE PURSUANT TO THE TERMS AND CONDITIONS OF THIS AGREEMENT. THIS AGREEMENT IS BETWEEN YOU (AS AN INDIVIDUAL OR LEGAL ENTITY) AND YAMAHA CORPORATION ("YAMAHA").

BY DOWNLOADING, INSTALLING, COPYING, OR OTHERWISE USING THIS SOFTWARE YOU ARE AGREEING TO BE BOUND BY THE TERMS OF THIS LICENSE. IF YOU DO NOT AGREE WITH THE TERMS, DO NOT DOWNLOAD, INSTALL, COPY, OR OTHERWISE USE THIS SOFTWARE. IF YOU HAVE DOWNLOADED OR INSTALLED THE SOFTWARE AND DO NOT AGREE TO THE TERMS, PROMPTLY DELETE THE SOFTWARE.

1. GRANT OF LICENSE AND COPYRIGHT

Yamaha hereby grants you the right to use the software program(s) and data ("SOFTWARE") accompanying this Agreement. The term SOFTWARE shall encompass any updates to the accompanying software and data. The SOFTWARE is owned by Yamaha and/or Yamaha's licensor(s), and is protected by relevant copyright laws and all applicable treaty provisions. While you are entitled to claim ownership of the data created with the use of SOFTWARE, the SOFTWARE will continue to be protected under relevant copyrights.

- **You may** use the SOFTWARE on **your computer(s)**.
- **You may** make one or reasonable copies of the SOFTWARE in machine-readable form for backup purposes only, if the SOFTWARE is on media where such backup copy is permitted. On the backup copy, you must reproduce Yamaha's copyright notice and any other proprietary legends that were on the original copy of the SOFTWARE.
- **You may** permanently transfer to a third party all your rights in the SOFTWARE, provided that you do not retain any copies and the recipient reads and agrees to the terms of this Agreement.

2. RESTRICTIONS

- **You may not** engage in reverse engineering, disassembly, decompilation or otherwise deriving a source code form of the SOFTWARE by any method whatsoever.
- **You may not** reproduce, modify, change, rent, lease, or distribute the SOFTWARE in whole or in part, or create derivative works of the SOFTWARE.
- **You may not** electronically transmit the SOFTWARE from one computer to another or share the SOFTWARE in a network with other computers.
- **You may not** use the SOFTWARE to distribute illegal data or data that violates public policy.
- **You may not** initiate services based on the use of the SOFTWARE without permission by Yamaha Corporation.

Copyrighted data, including but not limited to MIDI data for songs, obtained by means of the SOFTWARE, are subject to the following restrictions which you must observe.

- Data received by means of the SOFTWARE may not be used for any commercial purposes without permission of the copyright owner.
- Data received by means of the SOFTWARE may not be duplicated, transferred, or distributed, or played back or performed for listeners in public without permission of the copyright owner.
- The encryption of data received by means of the SOFTWARE may not be removed nor may the electronic watermark be modified without permission of the copyright owner.

3. TERMINATION

This Agreement becomes effective on the day that you receive the SOFTWARE and remains effective until terminated. If any copyright law or provisions of this Agreement is violated, the Agreement shall terminate automatically and immediately without notice from Yamaha. Upon such termination, you must immediately destroy the licensed SOFTWARE, any accompanying written documents and all copies thereof.

4. DISCLAIMER OF WARRANTY ON SOFTWARE

You expressly acknowledge and agree that use of the SOFTWARE is at your sole risk. The SOFTWARE and related documentation are provided "AS IS" and without warranty of any kind. NOTWITHSTANDING ANY OTHER PROVISION OF THIS AGREEMENT, YAMAHA EXPRESSLY DISCLAIMS ALL WARRANTIES AS TO THE SOFTWARE, EXPRESS, AND IMPLIED, INCLUDING BUT NOT LIMITED TO THE IMPLIED WARRANTIES OF MERCHANTABILITY, FITNESS FOR A PARTICULAR PURPOSE AND NON-INFRINGEMENT OF THIRD PARTY RIGHTS. SPECIFICALLY, BUT WITHOUT LIMITING THE FOREGOING, YAMAHA DOES NOT WARRANT THAT THE SOFTWARE WILL MEET YOUR REQUIREMENTS, THAT THE OPERATION OF THE SOFTWARE WILL BE UNINTERRUPTED OR ERROR-FREE, OR THAT DEFECTS IN THE SOFTWARE WILL BE CORRECTED.

5. LIMITATION OF LIABILITY

YAMAHA'S ENTIRE OBLIGATION HEREUNDER SHALL BE TO PERMIT USE OF THE SOFTWARE UNDER THE TERMS HEREOF. IN NO EVENT SHALL YAMAHA BE LIABLE TO YOU OR ANY OTHER PERSON FOR ANY DAMAGES, INCLUDING, WITHOUT LIMITATION, ANY DIRECT, INDIRECT, INCIDENTAL OR CONSEQUENTIAL DAMAGES, EXPENSES, LOST PROFITS, LOST DATA OR OTHER DAMAGES ARISING OUT OF THE USE, MISUSE OR INABILITY TO USE THE SOFTWARE, EVEN IF YAMAHA OR AN AUTHORIZED DEALER HAS BEEN ADVISED OF THE POSSIBILITY OF SUCH DAMAGES. In no event shall Yamaha's total liability to you for all damages, losses and causes of action (whether in contract, tort or otherwise) exceed the amount paid for the SOFTWARE.

6. THIRD PARTY SOFTWARE

Third party software and data ("THIRD PARTY SOFTWARE") may be attached to the SOFTWARE. If, in the written materials or the electronic data accompanying the Software, Yamaha identifies any software and data as THIRD PARTY SOFTWARE, you acknowledge and agree that you must abide by the provisions of any Agreement provided with the THIRD PARTY SOFTWARE and that the party providing the THIRD PARTY SOFTWARE is responsible for any warranty or liability related to or arising from the THIRD PARTY SOFTWARE. Yamaha is not responsible in any way for the THIRD PARTY SOFTWARE or your use thereof.

- Yamaha provides no express warranties as to the THIRD PARTY SOFTWARE. IN ADDITION, YAMAHA EXPRESSLY DISCLAIMS ALL IMPLIED WARRANTIES, INCLUDING BUT NOT LIMITED TO THE IMPLIED WARRANTIES OF MERCHANTABILITY AND FITNESS FOR A PARTICULAR PURPOSE, as to the THIRD PARTY SOFTWARE.
- Yamaha shall not provide you with any service or maintenance as to the THIRD PARTY SOFTWARE.
- Yamaha is not liable to you or any other person for any damages, including, without limitation, any direct, indirect, incidental or consequential damages, expenses, lost profits, lost data or other damages arising out of the use, misuse or inability to use the THIRD PARTY SOFTWARE.

7. GENERAL

This Agreement shall be interpreted according to and governed by Japanese law without reference to principles of conflict of laws. Any dispute or procedure shall be heard before the Tokyo District Court in Japan. If for any reason a court of competent jurisdiction finds any portion of this Agreement to be unenforceable, the remainder of this Agreement shall continue in full force and effect.

8. COMPLETE AGREEMENT

This Agreement constitutes the entire agreement between the parties with respect to use of the SOFTWARE and any accompanying written materials and supersedes all prior or contemporaneous understandings or agreements, written or oral, regarding the subject matter of this Agreement. No amendment or revision of this Agreement will be binding unless in writing and signed by a fully authorized representative of Yamaha.

Special Notices

- The software and this manual are the exclusive copyrights of Yamaha Corporation.
- Please read carefully the Software Licensing Agreement at the front of this manual before installing the application.
- Copying of the software or reproduction of this manual in whole or in part by any means is expressly forbidden without the written consent of the manufacturer.
- Yamaha makes no representations or warranties with regard to the use of the software and documentation and cannot be held responsible for the results of the use of this manual and the software.
- Future upgrades of application and system software and any changes in specifications and functions will be announced at the following website. <http://www.yamahaproaudio.com/>
- The screen displays as illustrated in this manual are for instructional purposes, and may appear somewhat different from the screens which appear on your computer.
- The illustrations and LCD screens as shown in this owner's manual are for instructional purposes only, and may appear somewhat different from those on your instrument.
- Copying of the commercially available musical data including but not limited to MIDI data and/or audio data is strictly prohibited except for your personal use.
- Windows is the registered trademarks of Microsoft® Corporation.
- The company names and product names in this manual are the trademarks or registered trademarks of their respective companies.

When you use the DSP5D Editor, be sure to install the DME-N Network Driver of the following version.
For Windows XP/Vista : 1.2.0 or later
For Windows 7: 1.2.1 or later

DME-N Network Driver

To operate your Yamaha hardware from your computer via Ethernet, you'll need to install the DME-N Network Driver software.

DME-N Network Driver is software that transfers MIDI data back and forth between your computer and the hardware via Ethernet cable.

Connection of computer and the DSP5D

Connect the computer to the DSP5D by using an Ethernet cable via a network switch. When you connect the computer to the DSP5D directly, you can use either a crossover or straight cable.

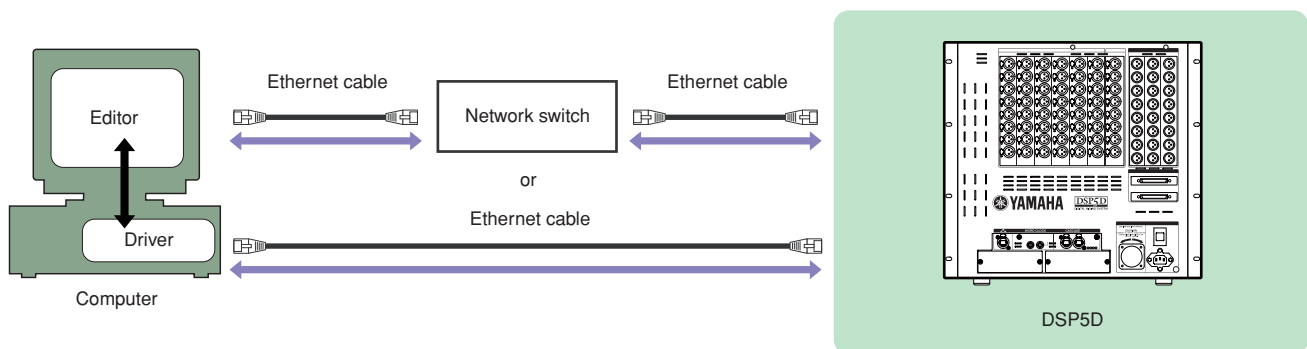

Minimum System Requirements

DME-N Network Driver applies to the system requirements of DSP5D Editor. Refer to the DSP5D Editor Installation Guide for details.

Installation

- 1** Log onto Windows with Administrator privileges.
- 2** Extract the data from the downloaded compressed file and open the “DME_Networkdrv_v****” folder.
“****” represents the version number.
- 3** Double-click on “setup.exe.”
When the setup has been initialized, a “Welcome” dialog box appears.
NOTE When running under Windows Vista / 7, the “User Account Control” dialog box may appear. Click [Continue].
- 4** Click [Next]. The DME-N Network Driver will be installed.
When installation is complete, a message appears indicating that setup has been completed.
- 5** In order for the newly installed DME-N Network Driver to take effect, select “Yes, I want to restart my computer now,” and click [Finish].
The computer will restart.

The DME-N Network Driver has been installed.

Uninstalling

Windows XP

- 1** Select [Start] → [Control Panel] → [Add or Remove Programs].
The “Add or Remove Programs” dialog box appears.
- 2** Click [Remove] for the DME-N Network Driver.
Follow the onscreen instructions to uninstall the driver.
NOTE If you attempt to reinstall the software after uninstalling it without first restarting your computer, the following message will appear and the install process will be aborted.
“Restart your computer, then run the installer.”
The installer should run normally after your computer has been restarted.

Windows Vista / 7

- 1** Select [Start] → [Control Panel] → [Programs and Features] or [Uninstall a program].
The “Uninstall or change a program” dialog box appears.
- 2** Select “Yamaha DME-N Network Driver” and click [Uninstall].
Follow the onscreen instructions to uninstall the driver.
NOTE The “User Account Control” dialog box may appear. Click [Continue].
NOTE If you attempt to reinstall the software after uninstalling it without first restarting your computer, the following message will appear and the install process will be aborted.
“Restart your computer, then run the installer.”
The installer should run normally after your computer has been restarted.

Setup

1 Log onto Windows with Administrator privileges.

NOTE In order to use the DME-N Network Driver, the computer and the DSP5D must be properly connected and configured. For details on connections, refer to “Connection of computer and the DSP5D”. For details on configuration, refer to “TCP/IP Settings” and “Troubleshooting (FAQ)”.

2 Select [Start] → [Control Panel].

The “Control Panel” will appear.

3 If the control panel appears as category view, switch the view as follows:

For Windows XP

Click [Switch to Classic View] in the upper left of the control panel.

For Windows Vista

Click [Classic View] in the upper left of the control panel.

for Windows 7

Click [View by : Category] in the upper right of the control panel, and select “Large icons” or “Small icons”.

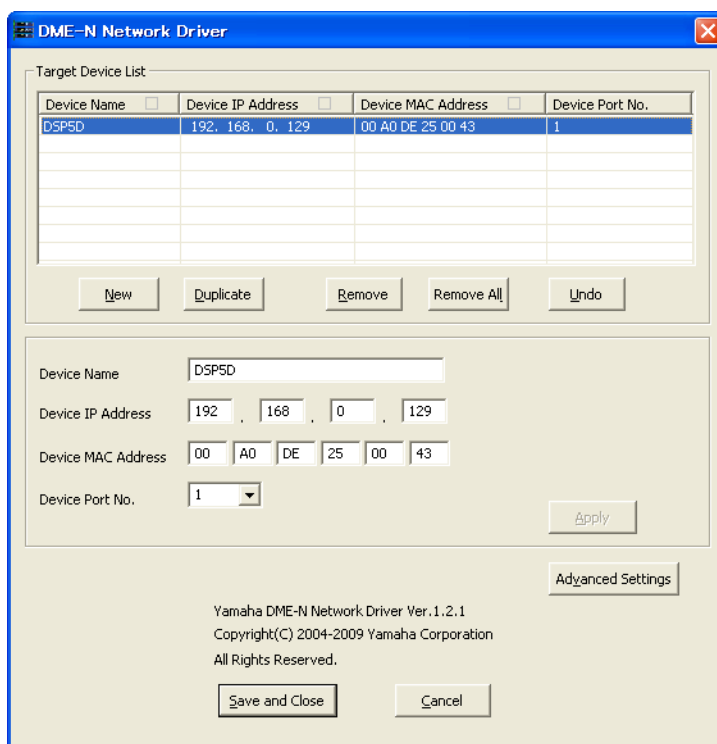

NOTE When running under Windows Vista / 7, the “User Account Control” dialog box may appear. Click [Continue].

NOTE If an application that uses the DME-N Network Driver is running at this time the “Quit all applications that use the DME-N Network Driver in order to change settings.” message will appear. The DME-N Network Driver settings cannot be changed while any application that uses the DME-N Network Driver is running.

4 Set up the driver parameters via the “DME-N Network Driver” window.

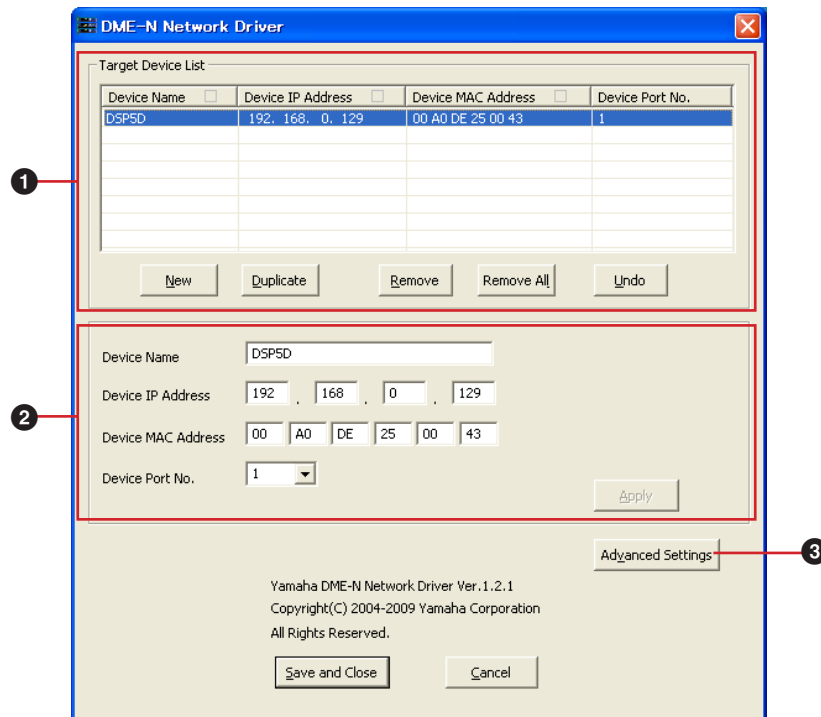

1 Target Device List

The name, IP address, MAC address, and MIDI port number of all devices registered to communicate with the DME-N Network Driver are shown in this list. Click the title bars to sort accordingly.

When a device is selected in the list, information related to that device will appear in the device information area (2) below the list.

Device Name

This column lists the names of devices registered to communicate with the DME-N Network driver. When a device is selected in the list its name also appears in the Device Name field in the device information area (2) below the list.

Device IP Address

The IP address of the corresponding device. When a device is selected in the list its IP address also appears in the Device IP Address field in the device information area (2) below the list.

Device MAC Address

The MAC address of the corresponding device. When a device is selected in the list its MAC address also appears in the Device MAC Address field in the device information area (2) below the list.

Device Port No.

The MIDI port number of the corresponding device. When a device is selected in the list its MIDI port number also appears in the Device Port No. field in the device information area (2) below the list.

[New] Button

Click this button to add a new device to the list. Edit the device's parameters as required via the fields in the device information area (2) below the list, then click the [Apply] button to add the specified device.

[Duplicate] Button

This button adds a device to the list by copying the data from the currently selected device. Edit the new device's parameters as required via the fields in the device information area (2) below the list, then click the [Apply] button to add the specified device.

[Remove] Button

Deletes the selected device from the list. If the removed device is not the lowest device in the list, all devices below the removed device will be shifted upward to maintain the continuity of the list.

[Remove ALL] Button

Deletes all devices from the list.

[Undo] Button

This button provides a one-step undo function that allows you to undo a single operation and revert to the previous state. The [Undo] button will be grayed out and inaccessible immediately after an undo operation or after the control panel is launched.

2 Device Information

When a device that is registered for communication with the DME-N Network Driver is selected in the Target Device List, the communication parameters for that device can be viewed and edited in the Device Information fields.

Device Name

This is the name of the device selected in the Target Device List. The initial default settings are "UNIT1" through "UNIT256," but the name can be edited as required in the Device Name field.

Device IP Address

The IP address of the device selected in the Target Device List can be set via these fields. The IP address of the DSP5D can be checked in the PREFERENCE 2 screen on the PM5D console if the DSP5D is cascade-connected to the PM5D. If the DSP5D is used alone, refer to "Connect the DSP5D to your computer via Ethernet" of the DSP5D owner's manual and "Console Setup" of the PM5DV2/DSP5D Editor owner's manual.

NOTE The IP address must be set properly or communication with the device will not be possible.

Device MAC Address

The MAC (Media Access Control) address of the device selected in the Target Device List can be set via these fields. The MAC address of each device is permanently assigned when the device is manufactured and cannot be changed. The MAC address parameter is included to prevent data from being sent to the wrong device if the IP address is inadvertently set incorrectly. The MAC address of the DSP5D can be checked in the PREFERENCE 2 screen on the PM5D console if the DSP5D is cascade-connected to the PM5D. If the DSP5D is used alone, it can be searched using the [Advanced Settings] button after setting the IP address properly. For details on the default value of IP address, refer to "Connect the DSP5D to your computer via Ethernet" of the DSP5D owner's manual.

NOTE The MAC address must be set properly or communication with the device will not be possible.

NOTE The MAC address of the connected device cannot be changed.

Device Port No.

The MIDI port number of the device selected in the Target Device List can be set via this menu. The MIDI port number also functions as device ID number. It should be set to "1" for DSP5D.

NOTE The MIDI port number must be set properly or communication with the device will not be possible.

[Apply] Button

Click the [Apply] button after editing the Device Name, Device IP Address, Device MAC Address, or Device Port No. parameters to actually apply the changes. Also, devices added to the Target Device List (1) by pressing the [NEW] or [DUPLICATE] buttons will only actually be registered for communication with the DME-N Network Driver when the [Apply] button is pressed.

3 [Advanced Settings] Button

Opens the "Advanced Settings" dialog box.

This window provides access to advanced settings. For details refer to the ["Advanced Settings" Dialog Box](#) section.

4 [Save and Close] Button

Click the [Save and Close] button to close the "DME-N Network Driver" dialog box and save the settings. This button is not accessible while an application that is using the DME-N Network Driver is running.

NOTE Click the [Cancel] button if you want to close the window without saving any changes.

Advanced Setup

The “Advanced Settings” dialog box can be opened by clicking the [Advanced Settings] button in the “DME-N Network Driver” dialog box.

NOTE In order to search the MAC address, the IP addresses of the DSP5D and the computer must have been assigned properly. For the default value of IP address, refer to “Connect the DSP5D to your computer via Ethernet” of the DSP5D owner’s manual.

“Advanced Settings” Dialog Box

The parameters in the “Advanced Settings” dialog box set up the DME-N Network Driver for automatic device detection, and allow saving and loading setup files.

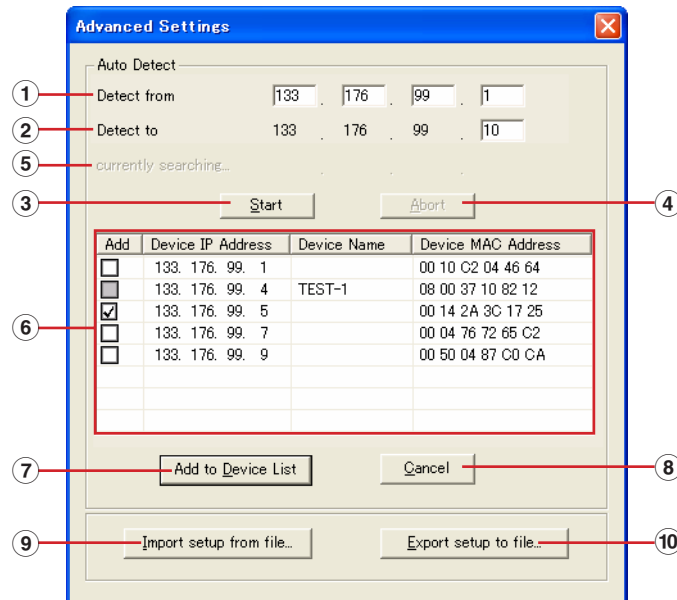

Auto Detect

Allows automatic detection of connected devices. A maximum of 254 addresses (***.***.***.1 through ***.***.***.254) can be detected.

NOTE Only MAC addresses of devices on the same subnet as the computer can be detected.

Before searching for MAC addresses make sure that the computer is connected to the subnet to be searched, and that an appropriate IP address is assigned.

① Detect from

Specifies the start IP address for automatic detection.

② Detect to

Specifies the end IP address for automatic detection.

③ [Start] Button

Initiates automatic detection, and causes the detected device list (⑥) to be updated accordingly. This button is grayed out and is not accessible during automatic detection.

④ [Abort] Button

Aborts automatic detection.

This button is grayed out when automatic detection is not in progress.

⑤ Currently searching

Displays the IP address being checked during automatic detection. No display when automatic detection is not in progress.

⑥ **Detected Device List**

This list shows all detected devices. No devices will be displayed initially.

[Add] Checkbox

Checked devices will be added to the Target Device List when the [Add to Device List] button (below) is clicked. Devices that are already registered cannot be checked.

Device IP Address

The IP address of the corresponding detected device.

Device Name

If a name has been registered for the detected device it will be displayed here, otherwise no name will be displayed.

Device MAC Address

The MAC address of the corresponding detected device.

⑦ **[Add to Device List] Button**

Devices with checked [Add] checkboxes will be added to the Target Device List when this button is clicked.

⑧ **[Cancel] Button**

Closes the dialog box without making any changes.

⑨ **[Import Setup from File] Button**

When working in a different environment it is possible to load a previously saved setup file. Click to open the "Open existing file" dialog box.

Select a setup file and then click the [Open] button to import the corresponding settings.

⑩ **[Export Setup to File] Button**

It is possible to save the setup data to a file that can then be reloaded when working in a different environment. Click to open the "Saves the current file with a new name" dialog box.

Enter a file name and click the [Save] button to save the setup file.

TCP/IP Settings

Windows XP

- 1 Select [Start] → [Control Panel].
The “Control Panel” is displayed.
- 2 If the control panel appears as category view, click [Switch to Classic View].
- 3 Double-click [Network Connections] → [Local Area Connection].
The “Local Area Connection Status” dialog box will be displayed.
NOTE If the “Local Area Connection properties” dialog box appears, skip ahead to step 5.
- 4 Click [Properties].
The “Local Area Connection Properties” dialog box will be displayed.
- 5 Select [Internet Protocol (TCP/IP)], then click [Properties].
The “Internet Protocol (TCP/IP) Properties” dialog box will be displayed.
- 6 Click [Use the following IP address].
- 7 Enter your computer’s IP address into [IP address], the Gateway’s IP address into [Default gateway], and “255.255.255.0” into [Subnet mask].

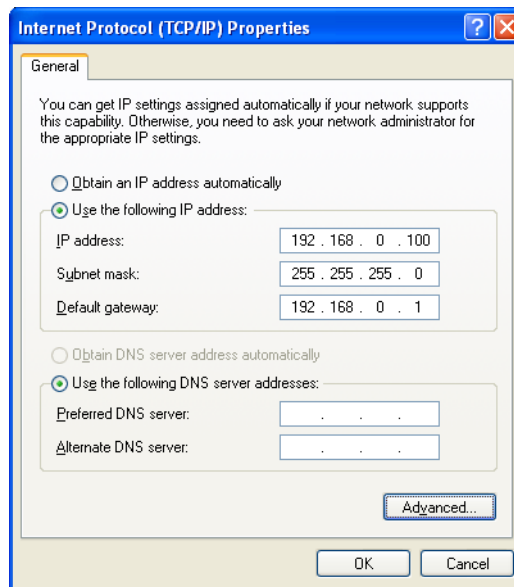

NOTE When installing on the same subnet as the DME unit(s), set the gateway’s host address to 254.

- 8 Click [OK].
- 9 Restart your computer.

Windows Vista / 7

- 1 Select [Start] → [Control Panel], then click or double-click [Network and Sharing Center] or [View network status and tasks].
The “Network and Sharing Center” is displayed.
- 2 Click [Manage network connection] or [Change Adapter settings] from the “Tasks” list located in the left side of “Network and Sharing Center” window, then double-click [Local Area Connection].
The “Local Area Connection properties” dialog box will be displayed.
NOTE The “User Account Control” dialog box may appear. Click [Continue].
NOTE If the “Local Area Connection properties” dialog box appears, skip ahead to step 4.
- 3 Click [Properties].
The “Local Area Connection properties” dialog box will be displayed.
NOTE The “User Account Control” dialog box may appear. Click [Continue].
- 4 Select [Internet Protocol Version 4(TCP/IPv4)], then click [Properties].
The “Internet Protocol Version 4(TCP/IPv4) Protocol” dialog box will be displayed.
- 5 Click [Use the following IP address].
- 6 Enter your computer’s IP address into [IP address], the Gateway’s IP address into [Default gateway], and “255.255.255.0” into [Subnet mask].

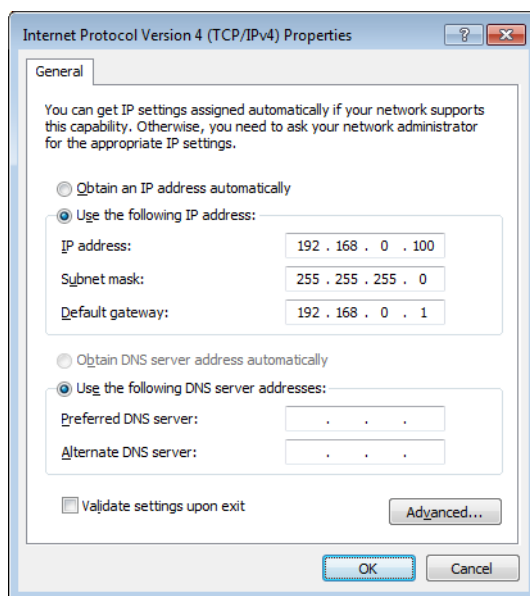

NOTE When installing on the same subnet as the DME unit(s), set the gateway’s host address to 254.

Troubleshooting (FAQ)

When controlling the DSP5D from your computer via Ethernet, the DSP5D does not operate correctly.

- Is the Ethernet cable connected correctly?

Refer to the “Connection of computer and the DSP5D” section.

- Is the DME-N Network Driver set up appropriately?

Refer to the “Setup” section.

- Did you enter an appropriate IP address of the DSP5D?

The IP address of the DSP5D can be checked in the PREFERENCE 2 screen on the PM5D console if the DSP5D is cascade-connected to the PM5D. If the DSP5D is used alone, refer to “Connect the DSP5D to your computer via Ethernet” of the DSP5D owner’s manual and “Console Setup” of the PM5DV2/DSP5D Editor owner’s manual. If you are connecting the DSP5D to your computer in a one-to-one connection, we recommend that you make the following initial settings.

IP address	192.168.0.129
Gateway address	192.168.0.1
Subnet mask	255.255.255.0

For details on settings when connecting to a LAN, refer to the DSP5D Editor installation guide. The IP address of the DSP5D must not conflict with that of any other device on the network.

- Did you enter the correct MAC address of the DSP5D?

The MAC address of the DSP5D can be checked in the PREFERENCE 2 screen on the PM5D console if the DSP5D is cascade-connected to the PM5D. If the DSP5D is used alone, it can be searched in the “Advanced Settings” dialog box when the IP address is known. If you don’t know the IP address of the DSP5D, initialize the DSP5D internal memory and search the IP address “192.168.0.129” in the “Advanced Settings” dialog box.

- Is the computer network setup appropriately?

Confirm the network setup by following the procedures in the “TCP/IP Settings” section.

If you are connecting the DSP5D to your computer in a one-to-one connection, we recommend that you make the following settings.

IP address	192.168.0.3
Subnet mask	255.255.255.0
Default gateway	192.168.0.1

For details on settings when connecting to a LAN, refer to the DSP5D Editor installation guide.

The IP address of the computer must not conflict with that of any other device on the network.

- Are the settings of the DSP5D and peripheral network devices (including switching hubs) appropriate?

Refer to the relevant owner’s manuals for the DSP5D and peripheral network devices (including switching hubs) for details.

- Have you selected an appropriate ports in the DSP5D Editor and Studio Manager?

Select the Device Name entered in the “DME-N Network Driver” dialog box as the input/output port settings of DSP5D Editor and Studio Manager.

- Are you using the latest DME-N Network Driver?

The latest driver can be downloaded from the Yamaha website <http://www.yamahaproaudio.com/>

- Are the settings of your security software appropriate?

If using Windows firewall:

For Windows XP

Click [Start] → [Control Panel] → [Windows Firewall] → [General] tab. Remove the [Don't allow exceptions] checkbox.

For Windows Vista

Click [Start] → [Control Panel] → [Windows Firewall] → [Change settings] → [General] tab. Remove the [Block all incoming connections] checkbox.

For Windows 7

Click [Start] → [Control Panel] → [Windows Firewall]. Confirm the communication with the DME-N Network Driver is permitted at [Inbound Rules] and [Monitoring] → [Firewall].

If using other security software:

Either set the security software to allow use of TCP port 12300 on the network card being used by the DME-N Network Driver, or disable the security software.