



CobraNet[®] INTERFACE CARD MY16-C

Owner's Manual

LINK
FAULT
Fid-FRY
PRIMARY

FCC INFORMATION (U.S.A.)

1. **IMPORTANT NOTICE: DO NOT MODIFY THIS UNIT!**

This product, when installed as indicated in the instructions contained in this manual, meets FCC requirements. Modifications not expressly approved by Yamaha may void your authority, granted by the FCC, to use the product.

2. **IMPORTANT:** When connecting this product to accessories and/or another product use only high quality shielded cables. Cable/s supplied with this product **MUST** be used. Follow all installation instructions. Failure to follow instructions could void your FCC authorization to use this product in the USA.

3. **NOTE:** This product has been tested and found to comply with the requirements listed in FCC Regulations, Part 15 for Class "B" digital devices. Compliance with these requirements provides a reasonable level of assurance that your use of this product in a residential environment will not result in harmful interference with other electronic devices. This equipment generates/uses radio frequencies and, if not installed and used according to the instructions found in the users manual, may cause interference harmful to the operation of

The above statements apply **ONLY** to those products distributed by Yamaha Corporation of America or its subsidiaries.

other electronic devices. Compliance with FCC regulations does not guarantee that interference will not occur in all installations. If this product is found to be the source of interference, which can be determined by turning the unit "OFF" and "ON", please try to eliminate the problem by using one of the following measures:

Relocate either this product or the device that is being affected by the interference.

Utilize power outlets that are on different branch (circuit breaker or fuse) circuits or install AC line filter/s.

In the case of radio or TV interference, relocate/reorient the antenna. If the antenna lead-in is 300 ohm ribbon lead, change the lead-in to co-axial type cable.

If these corrective measures do not produce satisfactory results, please contact the local retailer authorized to distribute this type of product. If you can not locate the appropriate retailer, please contact Yamaha Corporation of America, Electronic Service Division, 6600 Orangethorpe Ave, Buena Park, CA90620

* This applies only to products distributed by YAMAHA CORPORATION OF AMERICA.

(class B)

This device complies with Part 15 of the FCC Rules. Operation is subject to the following two conditions: (1) this device may not cause harmful interference, and (2) this device must accept any interference received, including interference that may cause undesired operation.

This Class B digital apparatus complies with Canadian ICES-003.

Cet appareil numérique de la classe B est conforme à la norme NMB-003 du Canada.

PRECAUTIONS

PLEASE READ CAREFULLY BEFORE PROCEEDING

* Please keep this manual in a safe place for future reference.



WARNING

Always follow the basic precautions listed below to avoid the possibility of serious injury or even death from electrical shock, short-circuiting, damages, fire or other hazards. These precautions include, but are not limited to, the following:

- Before installing the MY16-C in an audio device please check to make sure that the device is compatible with the MY16-C, and check possible restrictions regarding the maximum number of Yamaha and third-party expansion cards that can be simultaneously installed. Refer to the operation manual supplied with the audio device, and/or the Yamaha Pro Audio web site at: <http://www.yamahaproaudio.com/>
- Do not install the MY16-C card in any Yamaha products not specified by Yamaha for use with the MY16-C to avoid possible electrical shock, fire, or equipment damage.
- Do not attempt to disassemble or modify the card. Do not apply excessive force to card connectors or other card components. Mishandling of the card may lead to shock, fire hazard, or equipment failure.
- Be sure to disconnect the power cable of the main unit before installing this card (in order to eliminate shock hazard).
- Turn off all peripheral devices connected to the host device before installation, and unplug all related cables.



CAUTION

Always follow the basic precautions listed below to avoid the possibility of physical injury to you or others, or damage to the device or other property. These precautions include, but are not limited to, the following:

- Do not touch the metallic leads (pins) of the circuit board when handling the card. The pins are sharp and may cause hand cuts.
- Wear a pair of heavy gloves during installation to avoid scratching or cutting your hands on sharp edges.
- Avoid touching exposed connectors and metal parts to minimize the possibility of bad connections.
- Drain all static electricity from your clothing and body before handling the card. Static electricity can damage the card. Touch an exposed metal part of the host device or other grounded object beforehand.
- Do not drop the card or subject it to physical shock as this can result in breakage and/or malfunction.
- Do not drop screws or other small parts inside the card. If power is applied while screws or similar metal objects are loose inside the unit the card may malfunction or be damaged. If you cannot retrieve dropped objects yourself, refer the problem to qualified Yamaha service personnel.

Yamaha cannot be held responsible for damage caused by improper use or modifications to the device, or data that is lost or destroyed.

Table of contents

About CobraNet™	4
The MY16-C System	7
Controls & Functions	8
Clock Synchronization Modes	12
MY16-C Card Installation Procedure	15
Connection Examples	16
Specifications	18

Greetings

Thank you for choosing the Yamaha MY16-C CobraNet™ INTERFACE CARD.

The MY16-C is a CobraNet™* expansion card for use with compatible Yamaha professional audio equipment. Complying to CobraNet™ standards, the MY16-C allows transmission and reception of up to 32 channels (16 in/16 out) of uncompressed digital audio data.

* CobraNet™: An audio networking system developed by Peak Audio (a division of Cirrus Logic, Inc.) that allows real-time transmission and reception of multiple channels of uncompressed digital audio signals via a Fast Ethernet (100 megabits/sec.) network. A single network cable can handle a maximum of 64 channels (128 channels bidirectional) of audio data.

The Peak Audio home page can be viewed on the web at: <http://www.peakaudio.com/>

In order to take full advantage of the advanced features and performance provided by the MY16-C card we urge you to read this manual thoroughly, and keep it in a safe place for further reference.

Before installing the MY16-C in an audio device please check to make sure that the device is compatible with the MY16-C, and check possible restrictions regarding the maximum number of Yamaha and third-party expansion cards that can be simultaneously installed.

The Yamaha Pro Audio web site is at: <http://www.yamahaproaudio.com/>

Package Contents

- MY16-C card
- This manual

The illustrations in this document are for instructional purposes, and may appear somewhat different from the actual equipment.
CobraNet and Peak Audio are trademarks of Cirrus Logic, Inc.
Ethernet is a trademark of Xerox Corporation.
All other trademarks are the property of their respective holders and are hereby acknowledged.

About CobraNet™

■ CobraNet is ...

An audio networking system developed by Peak Audio (a division of Cirrus Logic, Inc.) that allows real-time transmission and reception of uncompressed digital audio signals via a Fast Ethernet network cable. The network can simultaneously handle up to 64 input and output channels, for a total of 128 channels (64 channels if repeater hubs are used). The maximum number of channels than can be handled in practical situations may be lower due to performance limitations imposed by the equipment used and the condition of the audio signal.

Currently, the CobraNet network will handle 16, 20, or 24-bit audio at sampling rates of 48 or 96 kHz. The CobraNet network is capable of transmitting control data at the same time as the audio signals. The types of control data transmitted are determined by the equipment used. The CobraNet network imposes a 5.33-millisecond (2.67 milliseconds or 1.33 milliseconds with some settings) latency on transferred audio signals.

Refer to the Peak Audio home page for more details: <http://www.peakaudio.com/>

■ Bundles

Audio is transmitted over the CobraNet network in units known as "bundles." These bundles are processed at the receiving end to reconstitute the original audio signals. In the case of the MY16-C a bundle can contain from 3 to 8 channels. Each bundle is identified by a number from 0 to 65,279, and audio transmission via the network becomes possible when the same bundle number is specified at both the transmitting and receiving devices. Bundles can be transmitted and received over the entire network as long as sufficient network resources are available. The system is designed so that each device can transmit and receive up to 8 bundles simultaneously, but the actual number of bundles that can be handled will depend on the capabilities of the equipment used. The MY16-C can be set to handle 2 transmit bundle numbers and 2 receive bundle numbers. The bundle numbers can be specified via the rotary switches on the MY16-C card itself, or via the device or software used by the device in which the card is installed. The procedure for setting the MY16-C bundle numbers is described in the "Controls & Functions" section on page 8.

■ Multicast Bundles and Unicast Bundles

Two types of bundle can be used with CobraNet: "multicast" bundles and "unicast" bundles. Multicast bundles can be transmitted from a single device to all devices on the network, while unicast bundles are transferred from a single transmitting device to a single receiving device or a limited number of receiving devices.

Unicast bundles are only sent to devices which have been set to the same bundle number as the transmitting device. Multicast bundles are sent to all devices on the network regardless of their settings, but only bundles with the specified bundle number(s) are processed. For this reason multicast bundles make heavy use of network resources and it is recommended that the maximum number of bundles be limited to 4 (32 channels). Unicast bundles should be employed when it is necessary to handle 5 or more bundles at a time.

Different number ranges are used for multicast and unicast bundles: multicast bundles are numbered 1 through 255, while unicast bundles are numbered 256 through 65,279.

Multicast Bundles

Multicast bundles transmitted from device A are sent to all devices on the network (B through D in the example).

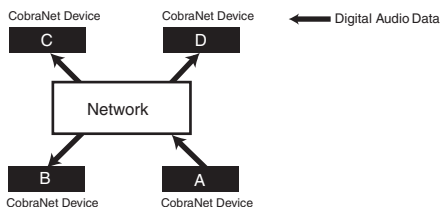

Unicast Bundles

Unicast bundles are received only by devices set to receive the same bundle numbers as the transmit bundle number of the transmitting device A (device D in this example).

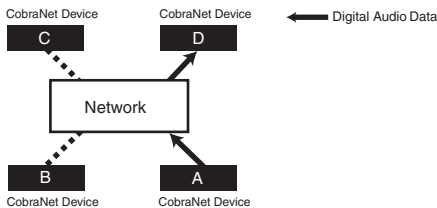

■ Conductor and Performers

On any CobraNet network one device generates a timing signal that all other devices receive and are synchronized to. The device that generates the synchronization signal is known as the “conductor,” while all other devices are “performers.”

The conductor for the network is automatically assigned and need not be specified by the operator. When an MY16-C is assigned to be the conductor for the network, the LED indicator to the right of the connector that is connected to the network will light orange. If the conductor fails for some reason, conductor status is automatically switched to another device on the network.

Since the conductor transmits the synchronization signal to the performers via the network cable, no separate word clock cables are required and the total number of cables used by the system is kept to a minimum. Digital audio devices that are not connected to the network, however, will need to receive a word clock signal from a device on the network in order to achieve synchronization.

NOTE Digital signals and control data are transmitted and received by all conductor and performer devices on the CobraNet network.

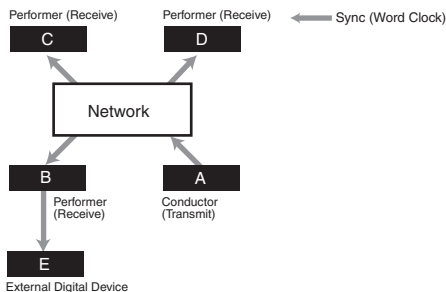

Conductors transmit the synchronization signal that is received and used by performers. Clock synchronization is necessary to transfer digital audio data to and from devices outside the CobraNet network. In this example device B on the CobraNet network sends the synchronization signal to external device E.

■ CobraNet Cables and Hubs

Category-5 metal cables can be used for runs of up to 100 meters, while multimode optical fiber cables can be used for runs of up to 2 kilometers.

“Cross” and “straight” Ethernet cables are available. “Cross” cables should be used for direct connection between two devices. Hubs and “straight” cables are required to connect 3 or more devices. Ethernet hubs are available in “repeater” and “switching” configurations. Switching hubs are recommended for use on CobraNet networks. The use of repeater hubs can result in excessive network traffic, thus reducing network efficiency.

It is best to use a repeater hub that has been tested and certified by Peak Audio.

A list is available at http://www.peakaudio.com/cobranet/tested_ethernet.html.

The MY16-C System

The internal signal flow of the MY16-C is shown in the illustration below.

16 audio inputs and 16 audio outputs are available, and for this example channels 1 ~ 8 are bundle 1, and channels 9 ~ 16 are bundle 2.

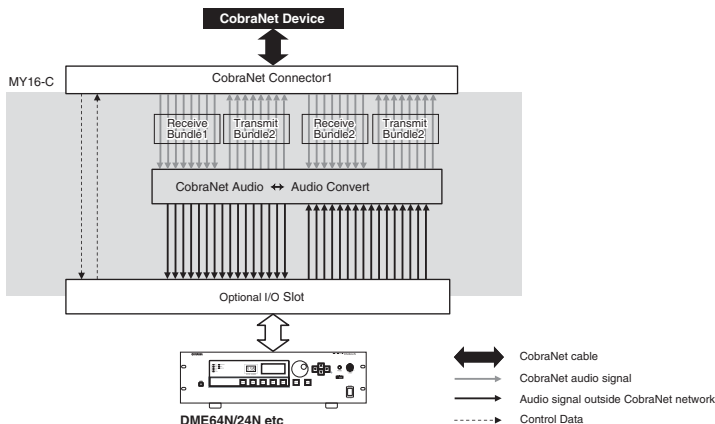

NOTE Depending on the setup, less than 8 channels may be handled by each bundle. The relationship between the settings and the number of channels that can be handled by each bundle is shown below.

Settings vs. Number of Channels per Bundle

Latency	Channels per Bundle					
	16 bit, 48kHz	20 bit, 48kHz	24 bit, 48kHz	16 bit, 96kHz	20 bit, 96kHz	24 bit, 96kHz
5.33 ms	8	8	7	4 ^{*1}	4 ^{*1}	3 ^{*1}
2.66 ms	8	8	8	4 ^{*1}	4 ^{*1}	4 ^{*1}
1.33 ms	8	8	8	4 ^{*1}	4 ^{*1}	4 ^{*1}

*1 Number of channels when 48-kHz channel pairs are combined to create single 96-kHz channels.

Channels per Bundle & Usable No. of Channels

Channels per Bundle	Usable No. of Channels	
	Bundle1	Bundle2
8	1-8	9-16
7	1-7	9-15
4	1,3,5,7	9,11,13,15
3	1,3,5	9,11,13

Controls & Functions

■ Panel Connectors and Switches

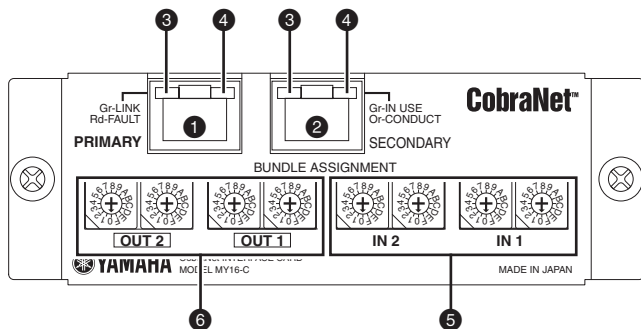

① [PRIMARY] and ② [SECONDARY] Connectors

These are 100Base-T Ethernet connectors. The MY16-C provides two Ethernet connectors to allow construction of redundancy networks employing dual (primary and secondary) circuits. The [PRIMARY] connector is for connection to the main circuit, while the [SECONDARY] connector is for connection to the backup circuit.

If a failure occurs on the PRIMARY circuit (e.g. a cable failure, accidental disconnection, switching hub failure, etc.) the SECONDARY circuit will automatically take over. Basic redundancy network setup is described on page 17.

Use STP (Shielded Twisted Pair) cables to protect against electromagnetic interference.

③ [LINK/FAULT] Indicators

These are the LED indicators to the left of the [PRIMARY] and [SECONDARY] connectors.

These indicators will light when a network cable is connected to the corresponding connector. The indicator for each connector will light green when a network cable is properly connected, and will flash while data is being properly transferred via the corresponding connector. If an error occurs on the connected network, the appropriate indicator will light or flash red.

If an indicator lights or flashes red, try disconnecting it from the corresponding Ethernet connector. The indicator will go out if a cable, hub, or other device connected to the network has failed. If the indicator remains lit or flashing even after the cable is disconnected, there may be a fault in the MY16-C card itself. In this case please refer the problem to qualified Yamaha service personnel.

④ [IN USE/CONDUCT] Indicators

These are the indicators to the right of the [PRIMARY] and [SECONDARY] connectors. These indicators will light when power has been properly applied to the MY16-C card. These indicators normally light green, but will light orange when the MY16-C is operating as the network conductor.

5 BUNDLE ASSIGNMENT [IN1] and [IN2] Rotary Switches

These switches set the receive bundle number for audio signals to be received over the CobraNet network. The [IN1] switches specify the receive bundle 1 number, and the [IN2] switches specify the receive bundle 2 number. Two rotary switches are used to specify each number. See "Bundle Number Setting Procedure" on page 15 for details.

6 BUNDLE ASSIGNMENT [OUT1] and [OUT2] Rotary Switches

These switches set the transmit bundle number for audio signals to be transmitted over the CobraNet network. The [OUT1] switches specify the transmit bundle 1 number, and the [OUT2] switches specify the transmit bundle 2 number. Two rotary switches are used to specify each number. See "Bundle Number Setting Procedure" on page 15 for details.

■ Circuit-board Switches

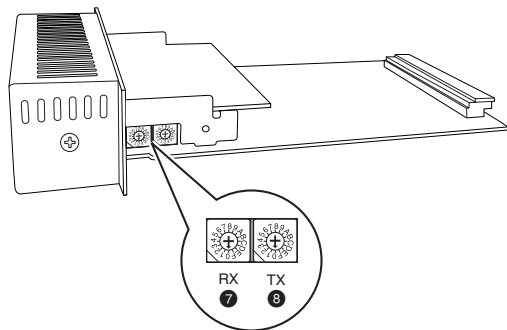

7 SERIAL ASSIGNMENT [RX] Rotary Switch

Sets the receive channel for the CobraNet serial control signal from channel 1 through channel 15. The control signals are received from a device that has been set to the matching transmit-channel number. No serial control reception occurs if this switch is set to "0".

8 SERIAL ASSIGNMENT [TX] Rotary Switch

Sets the transmit channel for the CobraNet serial control signal from channel 1 through channel 15. The control signals are sent to devices that have been set to the matching receive-channel number. No serial control transmission occurs if this switch is set to "0".



When adjusting rotary switches please use a screwdriver with a blade that matches the switch groove. Attempting to use a screwdriver that is too large or too small can damage the switch.

■ DIP Switches

The DIP switches on the MY16-C circuit board can be used to set audio resolution, latency, the clock synchronization mode, and clock frequency. All dip switches are OFF when the MY16-C is initially shipped.

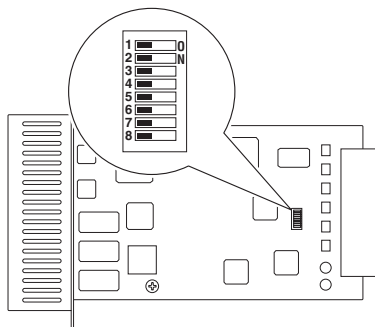

No.	Function
1	BIT
2	Fs
3	LATENCY 1
4	LATENCY 2
5	CLOCK 1
6	CLOCK 2
7	RESERVED 1
8	RESERVED 2

NOTE The RESERVED 1 and RESERVED 2 switches are reserved for functions to be implemented in the future. Leave both of these switches OFF.

■ Audio Bits (BIT)

DIP switch 1 sets the audio bit depth.

BIT	Audio Bit Depth
OFF	20 bit
ON	24 bit

■ Clock Frequency (Fs)

DIP switch 2 sets the audio clock frequency or sample rate.

Fs	Clock Frequency
OFF	48 kHz
ON	96 kHz

NOTE Set all other MY16-C cards installed in the same device to the same clock frequency. Set all CobraNet devices receiving and transmitting the same audio signals to the same clock frequency.

LATENCY 1/2

DIP switches 3 and 4 (LATENCY 1 and LATENCY 2) set the audio latency.

LATENCY 1	LATENCY 2	LATENCY
OFF	OFF	5.33 ms
OFF	ON	2.67 ms
ON	OFF	1.33 ms
ON	ON	Reserved

NOTE Set all CobraNet devices receiving and transmitting audio signals to the same latency.

Clock Synchronization Mode (CLOCK 1/2)

DIP switches 5 and 6 (CLOCK 1 and CLOCK 2) specify the clock synchronization mode to be used. See "Clock Synchronization Modes" on page 12 for more information.

CLOCK 1	CLOCK 2	Clock Synchronization Mode
OFF	OFF	Network synchronization
OFF	ON	Host synchronization 1
ON	OFF	Host synchronization 2
ON	ON	Reserved

Clock Synchronization Modes

The MY16-C provides a selection of three clock synchronization modes: Network synchronization, host synchronization 1, and host synchronization 2.

Network Synchronization

In this mode the MY16-C receives synchronization from the network. This is the normal synchronization mode. When the MY16-C is set to network synchronization, make sure that the audio device in which the MY16-C is installed is synchronized to the MY16-C clock.

An example of network synchronization

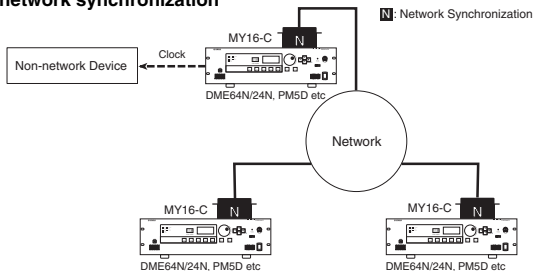

Host Synchronization 1

Use this mode if the device in which the MY16-C is installed is synchronized to a clock signal other than the CobraNet clock. When the Host Synchronization 1 mode is selected the MY16-C receives synchronization from the device in which it is installed (the "host"), and that clock signal is then supplied to the network. When the host Synchronization 1 mode is selected, make sure that the host device is set to feed a clock signal to the MY16-C card.

NOTE When using the Host Synchronization 1 mode make sure that the frequency of the clock signal supplied to the MY16-C is within ± 50 ppm of 48 kHz or 96 kHz. Proper operation is not guaranteed with clock frequencies outside this range, and problems with noise or instability may be encountered.

Examples of host synchronization 1

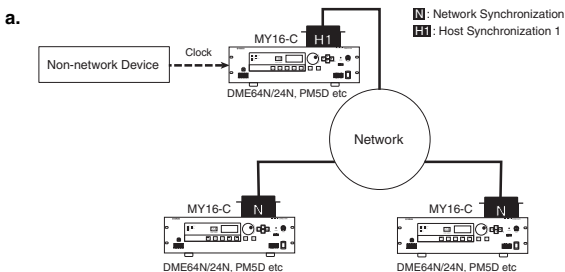

b.

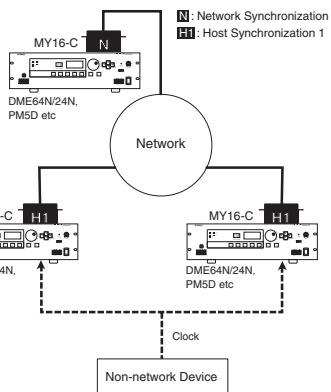

Host Synchronization 2

Use this mode if the MY16-C card is to be synchronized to the clock signal from another MY16-C card installed in the same device. When more than one MY16-C cards are installed in the same device and synchronization is to be received from the CobraNet network, set one of the installed MY16-C cards to Network Synchronization, and the other card(s) in the same device to Host Synchronization 2.

An example of host synchronization 2

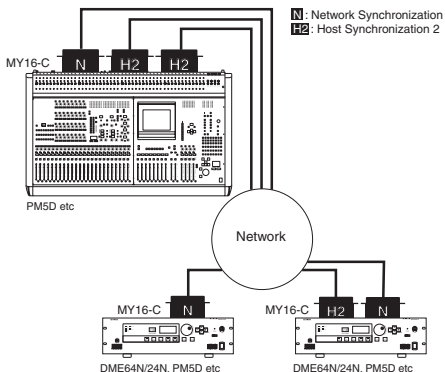

In some cases, all three synchronization modes are combined.

An example of all three synchronization modes used simultaneously.

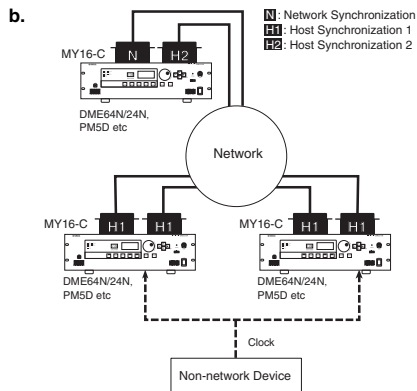
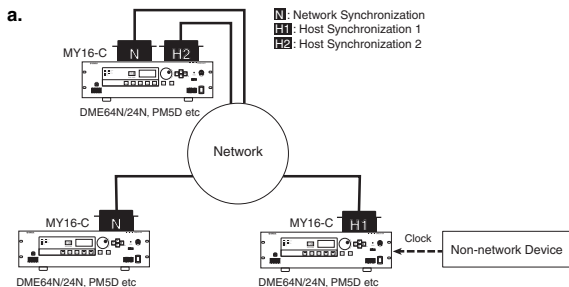

MY16-C Card Installation Procedure

 Carefully read the precautions on page 2 before installing the MY16-C.

- 1 Set the MY16-C circuit-board DIP switches and rotary switches as required for your application. Refer to "Circuit-board Switches" on page 9 for details about the switch settings. These switches cannot be accessed while the MY16-C card is installed in its host device. If you need to change the circuit board switch settings, turn power to the host device off, remove the MY16-C card, change the settings as required, then re-install the MY16-C card in the device.
- 2 Install the MY16-C card in an appropriate card slot on the host device. Refer to the operation manual of the host device for details. Make sure that the host device's power is turned off before installing the card.

 Be sure to disconnect the power cable of the main unit before installing the MY16-C.

 The screws function as part of the ground line, and should be tightened securely.

- 3 Connect the MY16-C card to another device on the CobraNet network using category-5 cable. Refer to the "Connection Examples" on page 16.
- 4 Set the bundle numbers as required.

Bundle Number Setting Procedure

Using the hexadecimal system, the left rotary switch sets the most significant bits of the number while the right switch sets the least significant bits. In short, the value of the left switch multiplied by 16 is added to the value of the right switch to produce 256 different values.

The relationship between the switch settings and bundle numbers is shown in the chart below. For example, if the left switch is set to "0" and the right switch is set to "A," the corresponding bundle number would be "10" in decimal. If the left switch is set to "1" and the right switch to "5," the bundle number would be 277 decimal.

Example: Bundle No.10



0 A

Example: Bundle No.277



1 5

Switch setting (Hexadecimal)	Bundle number (Decimal)
00	No transfer
01	1
02	2
:	:
0F	15
10	272
11	273
:	:
FE	510
FF	Ignored

 When adjusting rotary switches please use a screwdriver with a blade that matches the switch groove. Attempting to use a screwdriver that is too large or too small can damage the switch.

NOTE In some cases it is possible to set the bundle numbers from the device in which the MY16-C card is installed, or via software running on the host device. In such cases the device's bundle settings take priority over the card's rotary switches. It may also be possible to set a wider range of bundle numbers than is available via the rotary switches.

Connection Examples

Connecting Two Devices

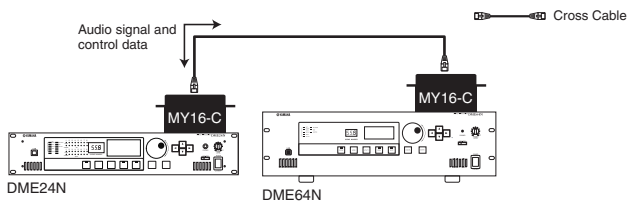

Connecting via a Hub

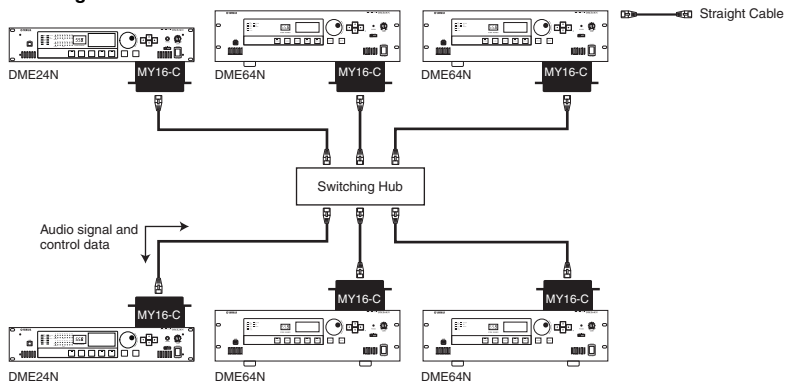

Connecting to a Mixer

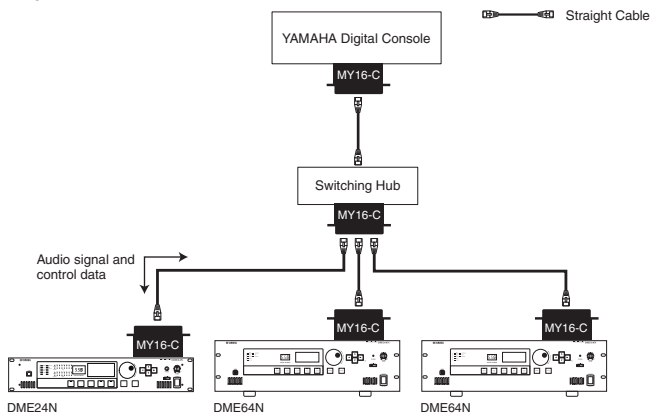

Connecting to Other CobraNet Devices

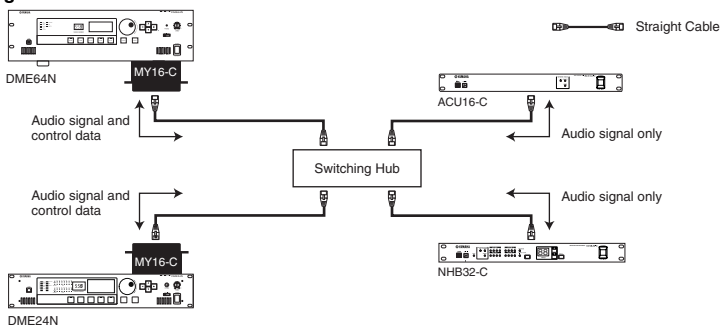

NOTE Not compatible with ACU16-C or NHB32-C control signals.

CobraNet Redundancy Network

NOTE Redundancy Networks

Redundancy networks employ dual (primary and secondary) circuits. Communication usually occurs over the primary circuit, but if a failure occurs on the primary circuit – cable failure, accidental disconnection, switch failure, etc. – the secondary circuit will automatically take over. Redundancy networks offer significantly higher reliability compared to single-circuit systems.

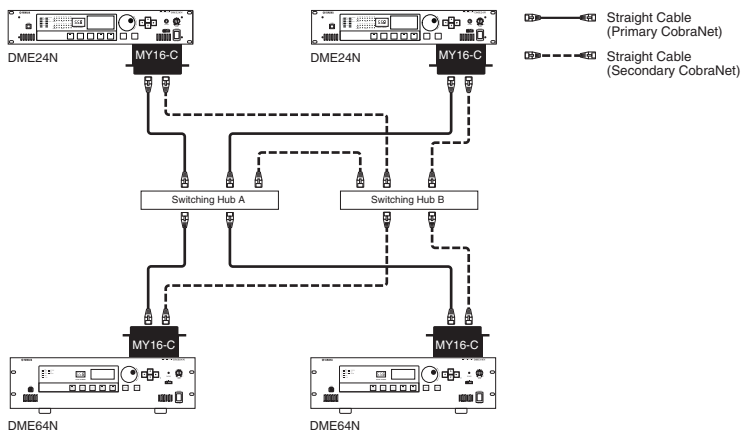

Specifications

Digital Input/Output Characteristics

<fs=48kHz>

Terminal	Format	Latency	Data Length	Audio	Connector
CobraNet Primary/Secondary	CobraNet	5.33ms	20bit	16ch Input / 16ch Output	RJ45
			24bit	14ch Input / 14ch Output	
		2.67ms	20bit	16ch Input / 16ch Output	
			24bit	16ch Input / 16ch Output	
		1.33ms	20bit	16ch Input / 16ch Output	
			24bit	16ch Input / 16ch Output	

	Min.	Typ.	Max.
Sampling Frequency Range	47.9976	48	48.0024

<fs=96kHz>

Terminal	Format	Latency	Data Length	Audio	Connector
CobraNet Primary/Secondary	CobraNet	5.33ms	20bit	8ch Input / 8ch Output	RJ45
			24bit	6ch Input / 6ch Output	
		2.67ms	20bit	8ch Input / 8ch Output	
			24bit	8ch Input / 8ch Output	
		1.33ms	20bit	8ch Input / 8ch Output	
			24bit	8ch Input / 8ch Output	

	Min.	Typ.	Max.
Sampling Frequency Range	95.9952	96	96.0048

General Specifications

Dimensions (mm)	120 x 40 x 200 (W x H x D)
Net Weight (kg)	0.6
Temperature Range (°C)	10~35 (Operating Temperature Range) -20~60 (Storage Temperature Range)
Accessories	Owner's Manual

CobraNet Ports (100Base-TX Ethernet, RJ-45)

Pin	Connection
1	TxD+
2	TxD-
3	RxD+
4	Unused
5	Unused
6	RxD-
7	Unused
8	Unused

Straight/Cross Cable Wiring Details

Straight Cables

Pins	
1	1
2	2
3	3
4	4
5	5
6	6
7	7
8	8

Cross Cables

Pins	
1	3
2	6
3	1
4	4
5	5
6	2
7	7
8	8

Dimensions

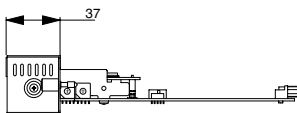
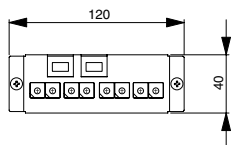
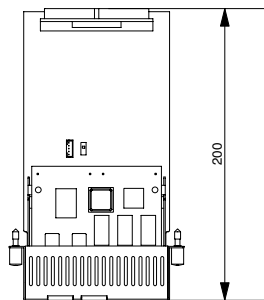

Unit: mm

- * Specifications and descriptions in this owner's manual are for information purposes only. Yamaha Corp. reserves the right to change or modify products or specifications at any time without prior notice. Since specifications, equipment or options may not be the same in every locale, please check with your Yamaha dealer.
- * Die technischen Daten und Beschreibungen in dieser Bedienungsanleitung dienen nur der Information. Yamaha Corp. behält sich das Recht vor, Produkte oder deren technische Daten jederzeit ohne vorherige Ankündigung zu verändern oder zu modifizieren. Da die technischen Daten, das Gerät selbst oder Sonderzubehör nicht in jedem Land gleich sind, setzen Sie sich im Zweifel bitte mit Ihrem Yamaha-Händler in Verbindung.
- * Les caractéristiques techniques et les descriptions du mode d'emploi ne sont données que pour information. Yamaha Corp. se réserve le droit de changer ou modifier les produits et leurs caractéristiques techniques à tout moment sans aucun avis. Du fait que les caractéristiques techniques, les équipements et les options peuvent différer d'un pays à l'autre, adressez-vous au distributeur Yamaha le plus proche.
- * Las especificaciones y descripciones de este manual del propietario tienen sólo el propósito de servir como información. Yamaha Corp. se reserva el derecho a efectuar cambios o modificaciones en los productos o especificaciones en cualquier momento sin previo aviso. Puesto que las especificaciones, equipos u opciones pueden no ser las mismas en todos los mercados, solicite información a su distribuidor Yamaha.



Yamaha Manual Library
<http://www2.yamaha.co.jp/manual/english/>

- This document is printed on chlorine free (ECF) paper with soy ink.
- Auf Umweltpapier mit Sojatinte gedruckt.
- Ce document a été imprimé sur du papier non blanchi au chlore avec de l'encre d'huile de soja.
- Este documento se ha impreso en papel sin cloro alguno, con tinta de soja.

U.R.G., Pro Audio & Digital Musical Instrument Division, Yamaha Corporation
© 2004 Yamaha Corporation

WC95460404MWCP3.2-01A0
Printed in JAPAN