

YAMAHA

MULTITRACK CASSETTE RECORDER

MT8X II

Owner's Manual

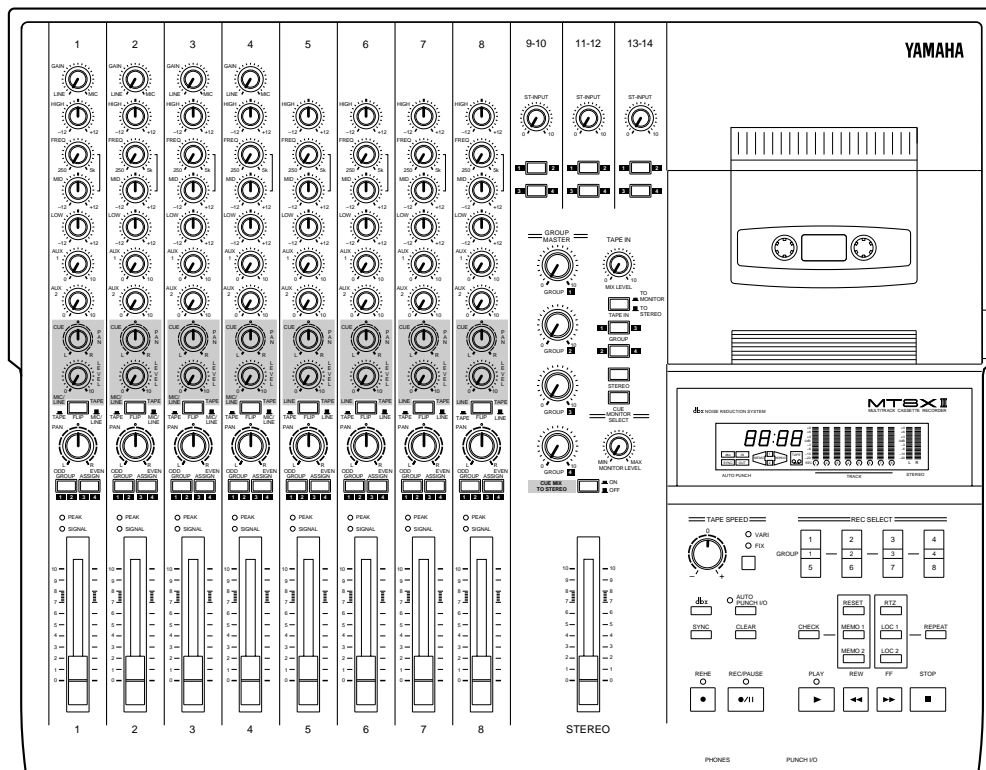

FCC INFORMATION (U.S.A.)

1. IMPORTANT NOTICE: DO NOT MODIFY THIS UNIT!

This product, when installed as indicated in the instructions contained in this manual, meets FCC requirements. Modifications not expressly approved by Yamaha may void your authority, granted by the FCC, to use the product.

2. IMPORTANT: When connecting this product to accessories and/or another product use only high quality shielded cables. Cable/s supplied with this product MUST be used. Follow all installation instructions. Failure to follow instructions could void your FCC authorization to use this product in the USA.

3. NOTE: This product has been tested and found to comply with the requirements listed in FCC Regulations, Part 15 for Class "B" digital devices. Compliance with these requirements provides a reasonable level of assurance that your use of this product in a residential environment will not result in harmful interference with other electronic devices. This equipment generates/uses radio frequencies and, if not installed and used according to the instructions found in the users manual, may cause interference harmful to the operation of other electronic devices. Compliance with FCC regulations does not guarantee that interference will not occur in all installations. If this product is found to be the source of interference, which can be determined by turning the unit "OFF" and "ON", please try to eliminate the problem by using one of the following measures:

Relocate either this product or the device that is being affected by the interference.

Utilize power outlets that are on different branch (circuit breaker or fuse) circuits or install AC line filter/s.

In the case of radio or TV interference, relocate/reorient the antenna. If the antenna lead-in is 300 ohm ribbon lead, change the lead-in to coaxial type cable.

If these corrective measures do not produce satisfactory results, please contact the local retailer authorized to distribute this type of product. If you can not locate the appropriate retailer, please contact Yamaha Corporation of America, Electronic Service Division, 6600 Orangethorpe Ave, Buena Park, CA 90620

* This applies only to products distributed by YAMAHA CORPORATION OF AMERICA.

IMPORTANT NOTICE FOR THE UNITED KINGDOM

Connecting the Plug and Cord

IMPORTANT: The wires in this mains lead are coloured in accordance with the following code:

BLUE : NEUTRAL

BROWN : LIVE

As the colours of the wires in the mains lead of this apparatus may not correspond with the coloured markings identifying the terminals in your plug proceed as follows:

The wire which is coloured BLUE must be connected to the terminal which is marked with the letter N or coloured BLACK.

The wire which is coloured BROWN must be connected to the terminal which is marked with the letter L or coloured RED.

Making sure that neither core is connected to the earth terminal of the three pin plug.

* This applies only to products distributed by YAMAHA - KEMBLE MUSIC (U.K.) LTD.

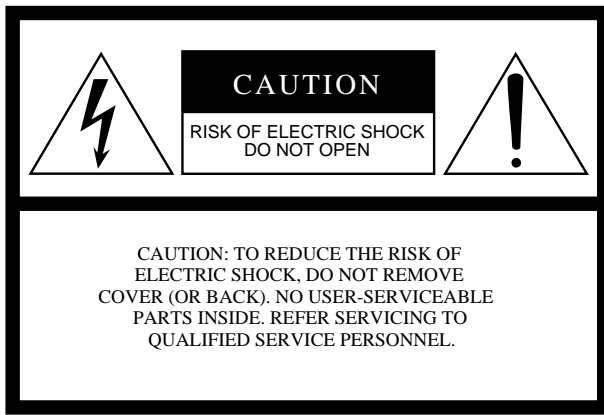

• Explanation of Graphical Symbols



The exclamation point within an equilateral triangle is intended to alert the user to the presence of important operating and maintenance (servicing) instructions in the literature accompanying the product.

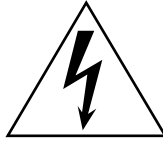

The lightning flash with arrowhead symbol within an equilateral triangle is intended to alert the user to the presence of uninsulated “dangerous voltage” within the product’s enclosure that may be of sufficient magnitude to constitute a risk of electric shock to persons.

SAFETY INSTRUCTIONS

1. Read Instructions — All the safety and operating instructions should be read before the appliance is operated.
2. Retain Instructions — The safety and operating instructions should be retained for future reference.
3. Heed Warnings — All warnings on the appliance and in the operating instructions should be adhered to.
4. Follow Instructions — All operating and use instructions should be followed.
5. Water and Moisture — The appliance should not be used near water – for example, near a bathtub, washbowl, kitchen sink, laundry tub, in a wet basement, or near a swimming pool, and the like.
6. Carts and Stands — The appliance should be used only with a cart or stand that is recommended by the manufacturer.

6A An appliance and cart combination should be moved with care. Quick stops, excessive force, and uneven surfaces may cause the appliance and cart combination to overturn.
7. Wall or Ceiling Mounting — The appliance should be mounted to a wall or ceiling only as recommended by the manufacturer.
8. Ventilation — The appliance should be situated so that its location or position does not interfere with its proper ventilation. For example, the appliance should not be situated on a bed, sofa, rug, or similar surface that may block the ventilation openings; or, placed in a built-in installation, such as a bookcase or cabinet that may impede the flow of air through the ventilation openings.
9. Heat — The appliance should be situated away from heat sources such as radiators, heat registers, stoves, or other appliances (including amplifiers) that produce heat.
10. Power Sources — The appliance should be connected to a power supply only of the type described in the operating instructions or as marked on the appliance.
11. Grounding or Polarization — The precautions that should be taken so that the grounding or polarization means of an appliance is not defeated.
12. Power-Cord Protection — Power-supply cords should be routed so that they are not likely to be walked on or pinched by items placed upon or against them, paying particular attention to cords at plugs, convenience receptacles, and the point where they exit from the appliance.
13. Cleaning — The appliance should be cleaned only as recommended by the manufacturer.
14. Nonuse Periods — The power cord of the appliance should be unplugged from the outlet when left unused for a long period of time.
15. Object and Liquid Entry — Care should be taken so that objects do not fall and liquids are not spilled into the enclosure through openings.
16. Damage Requiring Service — The appliance should be serviced by qualified service personnel when:
 - A. The power-supply cord or the plug has been damaged; or
 - B. Objects have fallen, or liquid has been spilled into the appliance; or
 - C. The appliance has been exposed to rain; or
 - D. The appliance does not appear to operate normally or exhibits a marked change in performance; or
 - E. The appliance has been dropped, or the enclosure damaged.
17. Servicing — The user should not attempt service the appliance beyond that described in the operating instructions.

Important

Read the Following Before Operating MT8XII

Warnings

- Do not locate MT8XII in a place subject to excessive heat or in direct sunlight. This could be a fire hazard.
- Do not place MT8XII in a place subject to excessive humidity or dust. This could be a fire and electrical shock hazard.
- Connect the supplied AC power cord only to an AC outlet of the type stated in this *Owner's Manual* or as marked on the main unit. Failure to do so is a fire and electrical shock hazard.
- Do not plug several devices into the same AC outlet. This can overload the AC outlet, and can be a fire and electrical shock hazard. It may also affect the performance of some devices.
- Do not place heavy objects on the power cord. A damaged power cord is a potential fire and electrical shock hazard.
- If the power cord is damaged (i.e., cut or a bare wire is exposed), ask your dealer for a replacement. Using MT8XII in this condition is a fire and shock hazard.
- Hold the AC power cord plug when disconnecting from an AC outlet. Never pull the cord. Damaging the power cord in this way is a potential fire and electrical shock hazard.
- Do not place small metal objects on top of MT8XII. Metal objects inside MT8XII are a fire and electrical shock hazard.
- Do not block the MT8XII ventilation holes. MT8XII has ventilation holes at the rear to prevent the internal temperature from rising. Blocked ventilation holes are a fire hazard.
- Do not try to modify MT8XII. This could be a fire and electrical shock hazard.
- MT8XII operating temperature is between 5°C and 35°C (41°F and 95°F).

Cautions

- Turn off all audio devices and speakers when connecting to MT8XII. Refer to the owner's manual for each device. Use the correct cables and connect as specified.
- MT8XII is a precision device. Handle it with care.
- If you notice any abnormality—such as smoke, odor, or noise—turn off MT8XII immediately. Remove the AC power cord from the AC outlet. Confirm that the abnormality is no longer present. Consult your dealer for repair. Using MT8XII in this condition is a fire and shock hazard.
- If a foreign object or water gets inside MT8XII, turn it off immediately. Remove the AC power cord from the AC outlet. Consult your dealer for repair. Using MT8XII in this condition is a fire and electrical shock hazard.
- If you plan not to use MT8XII for a long period of time (such as when you are on vacation), remove the AC power cord from the AC outlet. Leaving MT8XII connected is a fire hazard.
- Do not use benzene, thinner, cleaning detergent, or a chemical cloth to clean MT8XII.
- Use only a soft, dry cloth to clean MT8XII.

Interference

MT8XII uses high-frequency digital circuits that may cause interference on radios and televisions placed close to it. If interference does occur, relocate the affected equipment.

Copyright

© 1996 Yamaha Corporation. All rights reserved.

No part of the MT8XII software or this Owner's Manual may be reproduced or distributed in any form or by any means without the prior written authorization of Yamaha Corporation.

Trademarks

The dbx noise reduction system is manufactured based on a patent license from THAT Corporation.

dbx is a trademark of Carillon Electronics Corporation.

All other trademarks are the property of their respective holders.

Packing List

The MT8XII package should contain the following items. Make sure that you have them all.

- MT8XII Multitrack Recorder
- AC power cord
- Cleaning kit
- This Owner's Manual

Contact your Yamaha dealer if something is missing.

Keep This Manual For Future Reference

Table of Contents

1. Welcome to the MT8XII	1
MT8XII Features	1
Buying Cassette Tapes for the MT8XII	2
MT8XII Recording Format	2
About dbx Noise Reduction	2
MT8XII Maintenance	2
2. Touring the MT8XII	3
Topside View	3
Input Channels	4
Stereo Inputs	5
Master Section	6
Display	7
Transport Section	8
Rear Panel Connectors	10
Front Connectors	12
3. The First Session	13
Connecting the Power Cord	13
Turning On the MT8XII	13
Loading a Tape	13
Quick-Start System	14
Recording the First Track	15
Listening to the First Track	16
Overdubbing	16
Mixdown	18
Multi-Source Mixing	19
An Overview of Multitrack Recording	20
About Monitoring	21
4. Punch In/Out Recording	22
Punch In/Out	22
Manual Punch In/Out	23
Using the REC/PAUSE Button	23
Using the REC SELECT buttons	24
Using a Footswitch	25
Auto Punch In/Out	26
Setting the Punch In/Out Points	26
Rehearsing Auto Punch	27
Performing Auto Punch for Real	28
5. Ping-Pong Recording	29
Preparing for Ping-Pong	30
Rehearsing the Ping-Pong	30
Performing the Ping-Pong for Real	30
Checking the Ping-Pong Operation	31
Ping-Pong Notes	31
Ping-Pong with Overdub	32

6. Using Effects	33
Applying Effects at Mixdown	34
Applying Effects when Recording	34
Applying Effects with Ping-Pong	34
Patching In Signal Processors	35
7. Tape Speed & Mixing Tips	36
Using the Tape Speed Function	36
Mixing Tips	37
8. Quick Locate & Repeat Playback	38
RTZ (Return To Zero)	38
Memo 1/Memo 2	38
Entering the Memo Points	38
Locating the Memo Points	38
Checking the Memo Points	38
Clearing the Memo Points	38
Repeat Playback	39
9. The MT8XII & MIDI	40
Using the MT8XII in a MIDI System	40
SYNC Signal Formats	40
Connecting the MT8XII to a MIDI System	41
Striping the Tape	43
Synchronized Operation	43
10. MT8XII Applications	44
One-Take Recording	44
MIDI Home Studio	45
Multi-Source Mixing	46
Using the TAPE OUT/GROUP OUTs	47
Troubleshooting	48
Appendix	49
Maintaining the MT8XII	49
Specifications	51
Block Diagram	53
Dimensions	54
Glossary	55

1 Welcome to the MT8XII

Thank you for choosing the Yamaha MT8XII Multitrack Cassette Recorder. The MT8XII is a high-quality, easy-to-use multitrack cassette recorder that will allow you to capture your music at a very high level of quality. To take best advantage of your MT8XII, read this *Owner's Manual* thoroughly.

MT8XII Features

Mixer

The MT8XII mixer has 14 inputs and 4 groups. Including the 8 tape tracks and stereo TAPE IN, up to 20 inputs are available for mixdown.

- Continuously variable GAIN controls on input channels 1 through 4 allow the MT8XII to handle microphone and line-level signals with ease.
- Balanced XLR-type and phone jack inputs with switchable phantom power for condenser microphones on input channels 1 and 2.
- Insert jacks on input channels 1 and 2 for external processor patching.
- Musical three-band EQ (High, Mid, Low) with sweepable Mid on each input channel provides flexible tone-shaping capabilities.
- Two auxiliary sends for external effects processor patching.
- FLIP button allows you to route input signals to either the channel fader or CUE controls.
- Flexible monitoring of Groups, CUE, Stereo bus, and TAPE IN.
- Direct outputs for direct connection to another mixer.
- TAPE IN to monitor facility for monitoring during mixdown.
- Long-throw accurate faders.

Recorder

The MT8XII eight-track recorder is a precision engineered compact cassette transport.

- Logic-controlled tape mechanism ensures smooth and reliable operation.
- Hard Permalloy record-play head for long life and high performance.
- dbx™ noise reduction system provides a signal-to-noise ratio in excess of 80 dB.
- Variable pitch of approximately $\pm 12\%$.
- Two-color FLD (Fluorescent Display) shows recording and playback levels, plus a tape counter and other indicators.
- RTZ (Return To Zero) and two memo points for quick locate.
- Manual, footswitch, and automatic punch in/out functions, all with rehearse.
- Repeat playback and Auto Punch In/Out rehearsal repeat.
- Stripping Track 8 with a sync signal allows the MT8XII to synchronize MIDI sequencers and MIDI drum machines. The dbx noise reduction can be turned off just for Track 8, ensuring reliable synchronization operation.
- 9.5 cm/second tape speed for greater sonic performance.

Buying Cassette Tapes for the MT8XII

It's important that you buy the correct type of cassette tape for use with your MT8XII. You should buy high-quality Type II (High Bias, 70 μ s EQ) chrome cassettes of 90 minutes or less, such as TDK SA or Maxell UD-II or UD-XLIIS. Do not use metal tapes or 120 minute tapes. At normal speed, a 60-minute cassette provides about 15 minutes of recording time. That's because the tape runs at twice the speed of a normal cassette recorder and you can use only one side of the tape. The following table shows the available recording times with three standard tapes sizes.

Cassette Tape	MT8XII Recording Time (approximate)
C90	22.5 minutes
C60	15 minutes
C46	11.5 minutes

MT8XII Recording Format

Although the MT8XII uses the same type of cassettes as those used with normal cassette recorders, MT8XII tapes are not compatible with normal cassette players. A normal cassette recorder uses only two tracks (i.e., left and right stereo channels) and both tracks are recorded simultaneously. The MT8XII, on the other hand, can record eight tracks on a standard audio cassette. Even more importantly, you can record and playback these tracks individually. You can record up to four tracks simultaneously, or one at a time (a technique called overdub recording). Another major difference is that the MT8XII uses only one side of the cassette. There is no B side. If you turn over an MT8XII cassette you'll hear the tracks play backwards. This is because the MT8XII uses the full width of the tape to record eight tracks. The tape speed is also different. Normal cassette recorders run at 4.8 cm/second. Whereas the MT8XII runs at 9.5 cm/second, providing greater sonic performance.

About dbx Noise Reduction

The MT8XII uses the dbx noise reduction system to reduce tape hiss and keep your recordings clean and crisp. For the best performance, it's recommended that you use the dbx noise reduction for all your recordings. You should always use the dbx noise reduction system to play back tapes that were recorded with the dbx system on.

MT8XII Maintenance

The MT8XII requires regular maintenance to remain in top working condition. This consists of cleaning and demagnetizing the record-play head and other metal parts that are in contact with the cassette tape. See *Maintaining the MT8XII* on page 49 for more information.

2 Touring the MT8XII

This chapter takes you on a tour of the MT8XII, identifying the various parts to help you become familiar with your new recorder.

Topside View

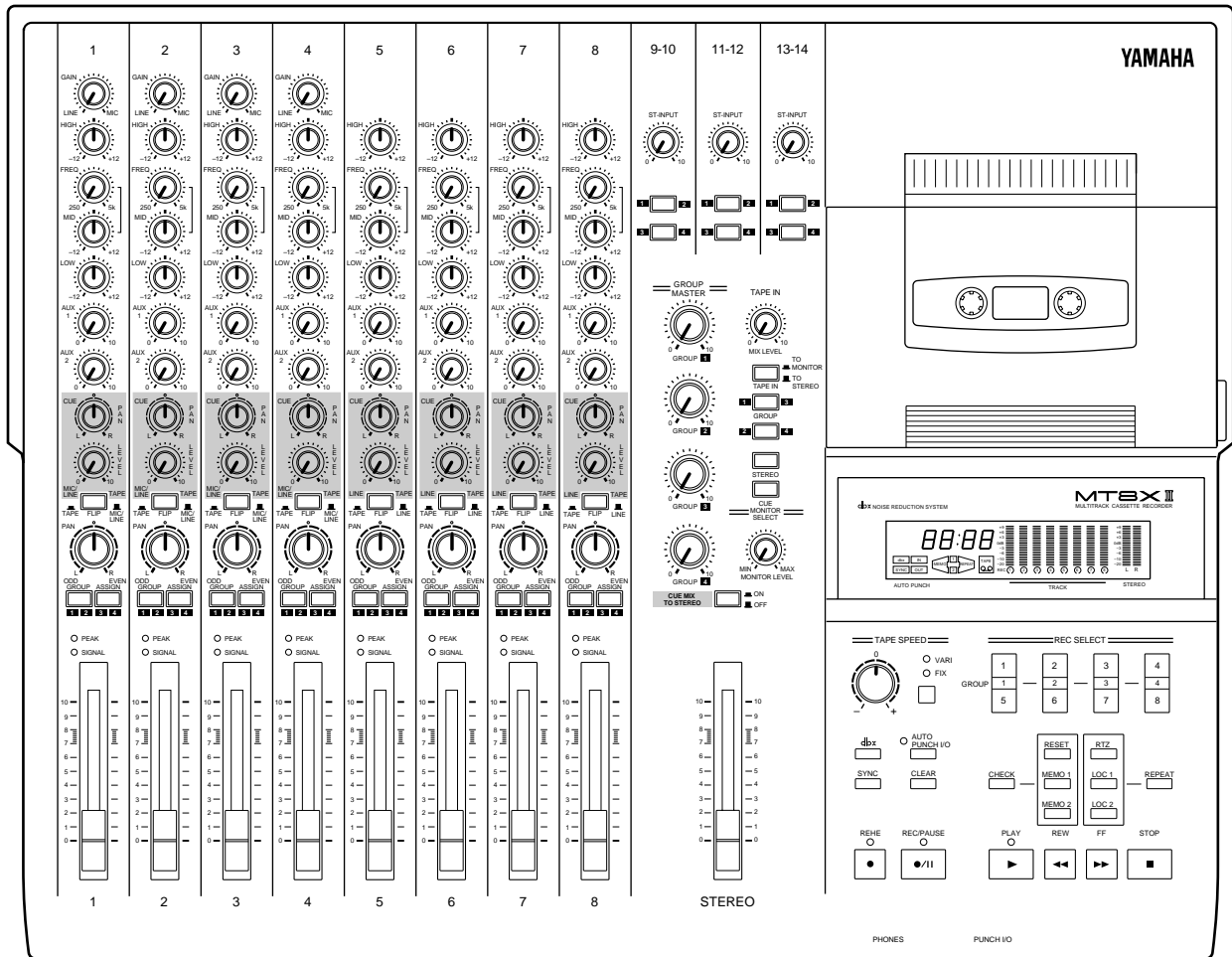

The individual sections of the MT8XII are explained on the following pages.

Input Channels

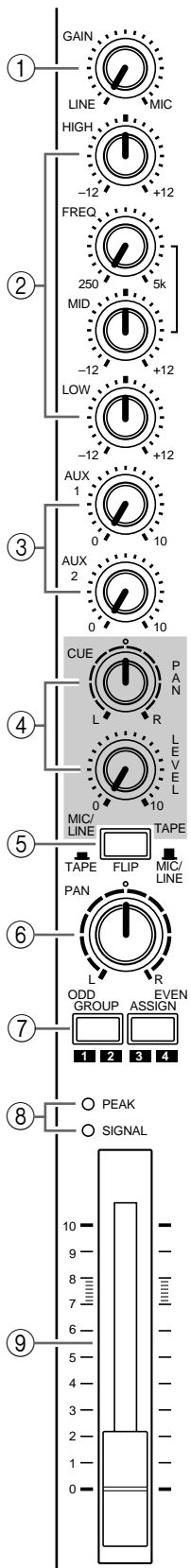

① **GAIN control (input channels 1–4)**

This rotary control adjusts the sensitivity of the MIC/LINE input so that both microphone and line-level signals can be handled with ease.

② **EQ controls**

These rotary controls are used to boost and cut the high, middle, and low frequency bands independently. The High and Low EQs are fixed frequency shelving types. The Mid EQ is a sweepable type. A flat setting (i.e., no boost or cut) can be set quickly using the controls' center detents.

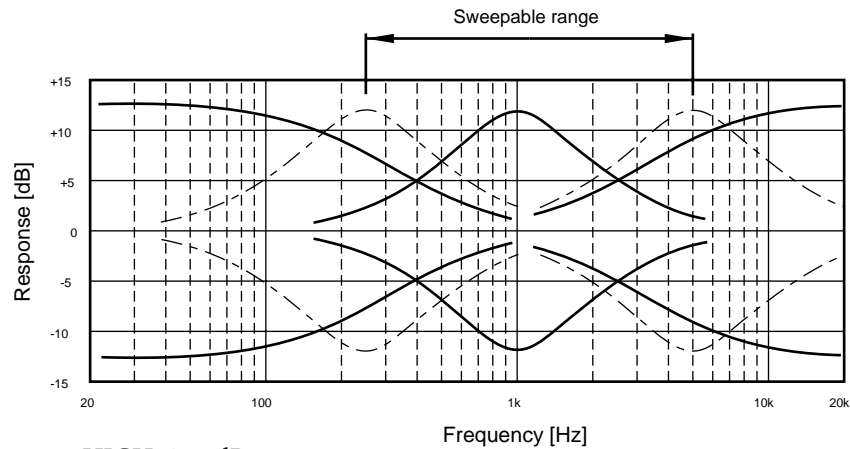

HIGH: ± 12 dB at

12 kHz—shelving type

MID: ± 12 dB at 250 Hz–5 kHz—sweepable type

LOW: ± 12 dB at 80 Hz—shelving type

③ **AUX controls**

These rotary controls are used to send the input channel signal to the AUX SEND outputs for processing by external effects processors.

④ **CUE PAN & LEVEL controls**

These two controls are used to adjust the level and pan of the CUE signal. The CUE signal source depends on the [FLIP] switch. With the [FLIP] switch set to the up position, the signal source is the tape track (i.e., the signal being recorded or played back). With the [FLIP] switch set to the down position, the signal source is the MIC/LINE inputs. This setting is typically used during mixdown, when the tape track signal is fed through the input channel. This allows you to connect extra sound sources using the CUE controls.

⑤ **FLIP switch**

This switch is used to select the signal sources for the input channel and CUE controls. With the [FLIP] switch in the up position, the MIC/LINE input signal is fed to the input channel and the tape signal is fed to the CUE controls. With the [FLIP] switch in the down position, however, this is reversed: the MIC/LINE input signal is fed to the CUE controls and the tape signal is fed to the input channel.

⑥ PAN control

This rotary control has two functions: For recording it's used in conjunction with the GROUP ASSIGN switches to assign the input channel signal to even and odd numbered groups. For mixdown it's used to pan (i.e., position) the signal in the stereo mix.

⑦ GROUP ASSIGN switches

These switches are used to assign (i.e., send) the input channel signal to groups. They work in conjunction with the PAN control. For example, with GROUP ASSIGN switch [1–2] ON and the PAN control set midway, the channel signal is sent equally to Groups 1 and 2. With the PAN control turned fully counterclockwise (L/ODD), however, the channel signal is sent only to Group 1. Likewise, when it is set fully clockwise, the signal is sent only to Group 2. The same principle applies to GROUP ASSIGN switch [3–4].

⑧ SIGNAL & PEAK indicators

The SIGNAL indicator shows when a signal is present in the input channel. It lights up when the signal is approximately 10 dB below the nominal level.

The PEAK indicator shows that a signal is about to clip. It lights up when the signal is 3 dB below the clip point. Adjust the GAIN control so that the PEAK indicator lights up momentarily at the loudest signals. For input channels 5–8 that do not have GAIN controls, adjust the output level of the source device.

⑨ Fader

This fader has two functions: For recording it's used to adjust the level of the input channel signal that's recorded to a track. For mixdown it's used to balance the input channel signal relative to the other input channel signals. For optimum performance, faders should be positioned about the 7–8 mark.

Stereo Inputs

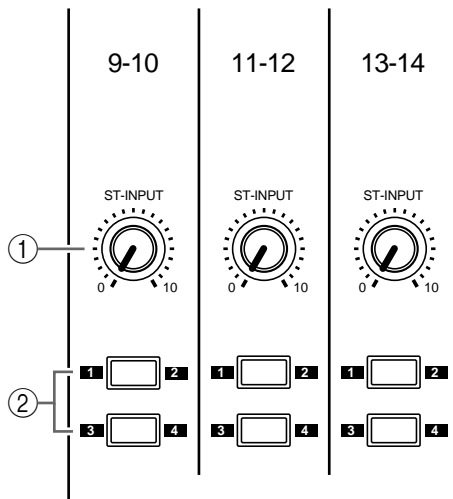

① ST INPUT controls

These rotary controls are used to adjust the level of the Stereo input signals that are sent to the Stereo bus for mixing. They're also used in conjunction with the GROUP ASSIGN switches to adjust the level of the Stereo input signals that are assigned to groups.

② GROUP ASSIGN switches

These switches are used to assign (i.e., send) the Stereo input signals to the groups. The left-channel signal is sent to odd Groups 1 and 3. While the right-channel signal is sent to even Groups 2 and 4. The Stereo input signals could be the stereo output signals from another mixer or external effects processor. Note that the Stereo input signals are always sent to the Stereo bus for mixing regardless of these switch settings.

Master Section

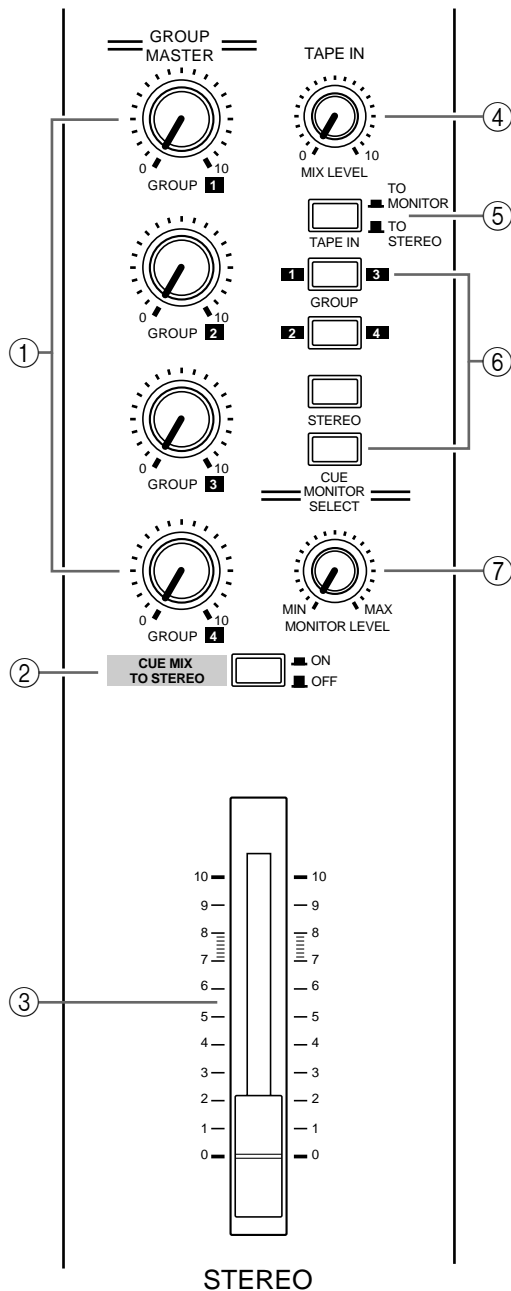

① GROUP MASTER level controls

These rotary controls adjust the levels of the group signals that are fed to the tracks.

② CUE MIX TO STEREO switch

This switch is used to feed the CUE bus signals through to the Stereo bus. It's used for multi-source mixing at mixdown.

③ STEREO fader

This fader is used to adjust the level of the stereo signal that is sent to the STEREO OUT. For optimum performance this fader should be positioned about the 7–8 mark.

④ TAPE IN MIX LEVEL control

This control adjusts the level of the TAPE IN signal that is fed to the Stereo bus when the TAPE IN switch is set to TO STEREO. It has no effect on the TAPE IN signal when the TAPE IN switch is set to TO MONITOR.

⑤ TAPE IN switch

This switch is used to assign the TAPE IN signal to either the Stereo bus or monitor. Select TO MONITOR when you want to monitor the output of the stereo master recorder during mixdown.

Select TO STEREO when you want to use TAPE IN as an extra stereo input and feed the signal into the stereo mix. Use the TAPE IN MIX LEVEL control to adjust the level.

Warning: Make sure the TAPE IN switch is set to TO MONITOR when recording through the TAPE INs and TAPE OUTs. If it's set to TO STEREO there will be a signal loop and oscillation may occur.

⑥ MONITOR SELECT switches

These switches are used to select the signal source for the MONITOR OUT and headphones.

GROUP—These switches select the Group buses as the monitor source. This allows you to monitor signals assigned to tracks. When only the [1–3] or [2–4] switch is pressed, the monitor signal is mono. Press both switches to monitor stereo signals.

STEREO—This switch selects the Stereo bus as the monitor source. This allows you to monitor the STEREO OUT signal and is typically used during mixdown.

CUE—This switch selects the CUE bus as the monitor source. This allows you to monitor track signals, which is useful for punch in/out.

⑦ MONITOR LEVEL control

This rotary control adjusts the level of the monitor signal that is sent to the MONITOR OUT and headphones.

Display

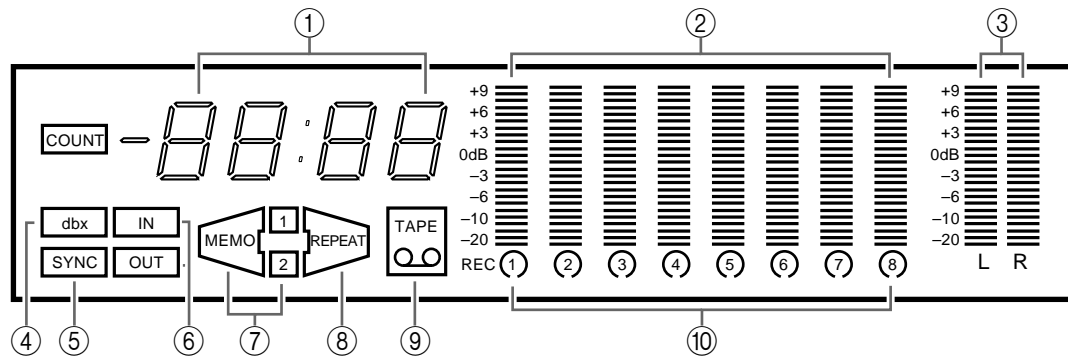

- ① **Tape counter**
The tape counter indicates the tape position.
- ② **Track level meters**
These meters show the track signal levels during recording and playback from -20 dB to $+9$ dB in eight steps. To turn on and off the Peak Hold function, hold down the [STOP] button and press the [RESET] button. With no tape loaded, the meters display group signal levels.
- ③ **Stereo level meters**
These meters show the STEREO OUT signal levels from -20 dB to $+9$ dB in eight steps. To turn on and off the Peak Hold function, hold down the [STOP] button and press the [RESET] button.
- ④ **dbx indicator**
This indicator lights up when the dbx noise reduction system is turned on.
- ⑤ **SYNC indicator**
This indicator lights up when the SYNC function is turned on. It stays on continuously for FSK sync and flashes for SMPTE sync.
- ⑥ **IN & OUT indicators**
These indicators show the status of the Auto Punch In/Out sequence.
- ⑦ **MEMO 1 & 2**
These indicators flash three times then light up continuously when the Memo 1 and Memo 2 location points are set.
- ⑧ **REPEAT indicator**
This indicator lights up when the Repeat Playback or Auto Punch In/Out Rehearse Repeat function is on.
- ⑨ **TAPE indicator**
This indicator light up when a tape is loaded into the MT8XII. If you press a transport button when no tape is loaded, the tape indicator flashes, indicating that no tape is loaded.
- ⑩ **Track record indicators**
These indicators show which tracks are selected for recording. They flash when a track is selected, and light up continuously during recording or rehearsal.

Transport Section

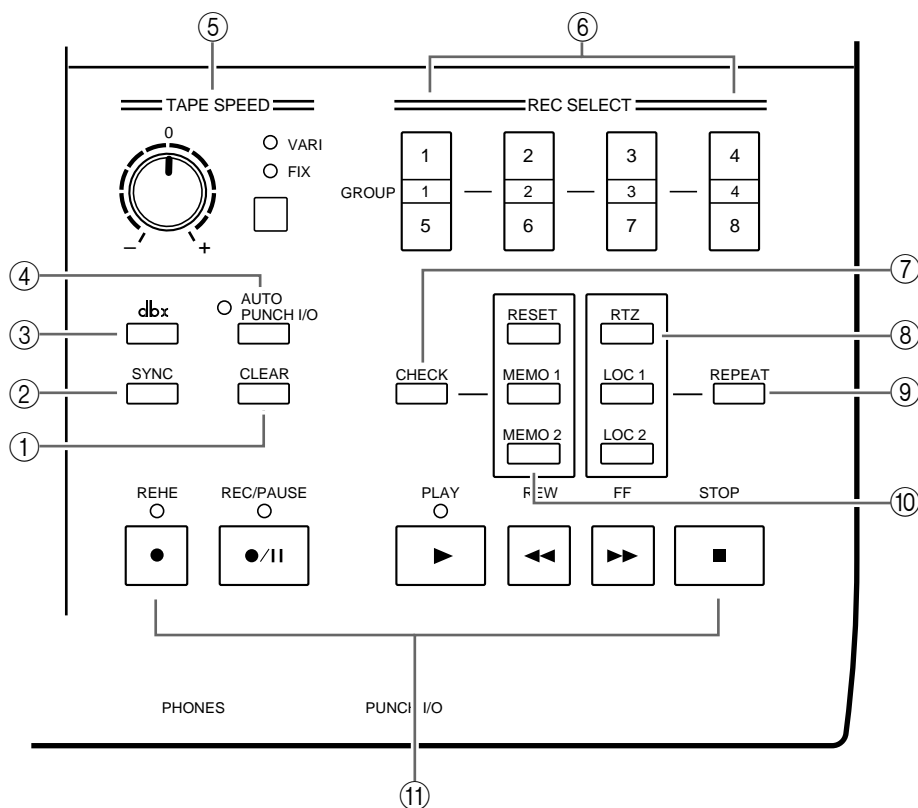

- ① **CLEAR button**
This button is used to cancel the Memo 1 and Memo 2 locate points. When the Auto Punch In/Out function is on, however, it cancels the specified punch in and punch out points. In this case, the Memo 1 and Memo 2 points are not cancelled.
- ② **SYNC button**
This button turns off the dbx noise reduction system for Track 8. It's used when recording and playing an FSK or SMPTE synchronization signal on Track 8. The SYNC indicator on the display lights up when the SYNC function is set for FSK and flashes when it's set for SMPTE.
- ③ **dbx button**
This button is used to turn on and off the dbx noise reduction system. The dbx indicator on the display lights up when dbx is turned on. The dbx system is turned on automatically each time the MT8XII is turned on.
- ④ **AUTO PUNCH I/O button and indicator**
This button is used to turn on and off the Auto Punch In/Out function. The adjacent indicator lights up when the Auto Punch In/Out function is on.
- ⑤ **TAPE SPEED control, switch, and indicators**
These controls are used to adjust the tape speed. When the speed is fixed at normal, the green FIX indicator lights up. When the speed is set to variable, the red VARI indicator lights up. The rotary control is used to increase or decrease the tape speed, and the adjacent switch is used to select the VARI and FIX modes.

⑥ **REC SELECT buttons**

These buttons are used to select tracks for recording. When a track is selected for recording, a flashing circle appears around the corresponding track select indicator on the display. Up to four tracks can be recorded simultaneously. You cannot record tracks that share the same REC SELECT button simultaneously (e.g., you cannot record on tracks 1 and 5 or 3 and 7 simultaneously).

⑦ **CHECK button**

This button is used to check the position of the Memo 1 and Memo 2 locate points. While holding down the [CHECK] button, press and hold the [MEMO 1] or [MEMO 2] to check a locate point. While checking a locate point, the corresponding memo indicator flashes on the display.

⑧ **RTZ, LOC 1, and LOC 2 buttons**

RTZ (Return To Zero)—This button is used to rewind the tape to the 00:00 position.

LOC 1 and LOC 2—These buttons are used to locate the Memo 1 and Memo 2 locate points. While the point is being located, the corresponding memo indicator flashes on the display.

⑨ **REPEAT button**

This button is used to turn on and off the Repeat Playback and Auto Punch In/Out Rehearse Repeat functions. The REPEAT indicator on the display lights up when the REPEAT function is turned on. If the Memo 1 and Memo 2 points are already set, Repeat Playback starts as soon as the [REPEAT] button is pressed. If only one memo point has been set, playback repeats between 00:00 and that memo point. After 16 repeats, the Repeat function stops.

Auto Punch In/Out Rehearse Repeat is started by pressing the [REPEAT] button after setting the punch-in and punch-out points with the Auto Punch In/Out function.

⑩ **RESET, MEMO 1, and MEMO 2 buttons**

RESET—This button is used to reset the tape counter to 00:00.

MEMO 1, MEMO 2—These buttons are used to store the Memo 1 and Memo 2 locate points. The respective memo indicator on the display flashes three times and then lights up continuously when a memo point is stored. Memo points are not stored when the MT8XII is turned off.

⑪ **Tape transport buttons**

REHE—This button is used to enter Rehearse Pause mode. The REHE indicator flashes if no tracks are selected for recording and lights up continuously when tracks are selected. Pressing the [PLAY] button starts the rehearsal.

REC/PAUSE—This button is used to enter Record Pause mode. The REC indicator flashes if no tracks are selected for recording and lights up continuously when tracks are selected. Pressing the [PLAY] button starts recording. Pressing this button while recording pauses recording. Pressing the [PLAY] button resumes recording.

PLAY—This button is used to start playback, start rehearsal, and start recording. It can also be used to cancel rehearsal and recording. In this case, normal playback continues from the point at which the [PLAY] button is pressed. The PLAY indicator lights up while playback is in progress.

REW—This button is used to rewind the tape. Holding down the button for more than one second rewinds the tape even faster. Press the [REW] button again to select normal rewind speed.

FF—This button is used to fast forward the tape. Holding down the button for more than one second fast forwards the tape even faster. Press the [FF] button again to select normal fast forward speed.

STOP—This button is used to stop playback, rewind, fast forward, rehearsal, recording, and set the meter Peak Hold function.

Rear Panel Connectors

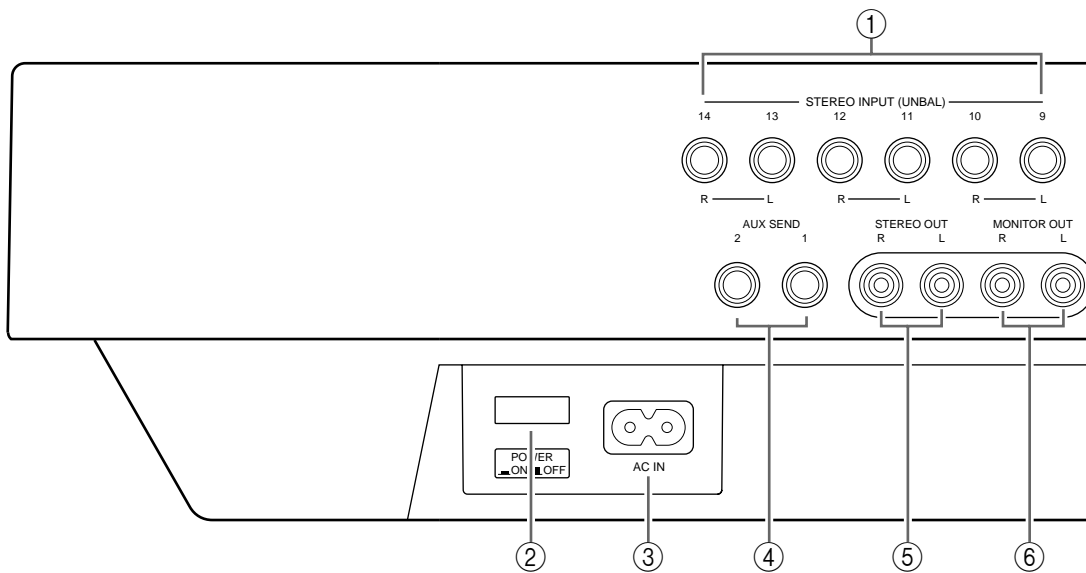

CAUTION

TO PREVENT ELECTRIC SHOCK,
MATCH WIDE BLADE OF PLUG TO
WIDE SLOT, FULLY INSERT.

① STEREO INPUT (UNBAL) 9–14

These 1/4-inch phone jacks are used to connect electronic musical instruments and other line-level sound sources that have stereo outputs. They can also be used to return the processed stereo signals from external effects processors. The processed signals can then be mixed into the MT8XII stereo mix or recorded to tracks.

② POWER ON/OFF switch

This switch is used to turn on and off the MT8XII.

③ AC IN

Connect the supplied power cord here.

④ AUX SEND

These 1/4-inch phone jacks are used to send the Aux Send signals to external effects processors. Connect them to the effects processors' inputs.

⑤ STEREO OUT

These phono jacks are used to connect a stereo master recorder for recording the final mix. The master recorder could be a DAT recorder, MiniDisc recorder, or cassette tape deck. Connect them to your master recorder's stereo inputs.

⑥ MONITOR OUT

These phono jacks are used to send the monitor signals to a stereo monitor amplifier and speakers. This could be a dedicated monitor amplifier and speakers or your hi-fi system. Connect them to the monitor amplifier's stereo inputs. The MONITOR OUT signal is the same as the headphone signal.

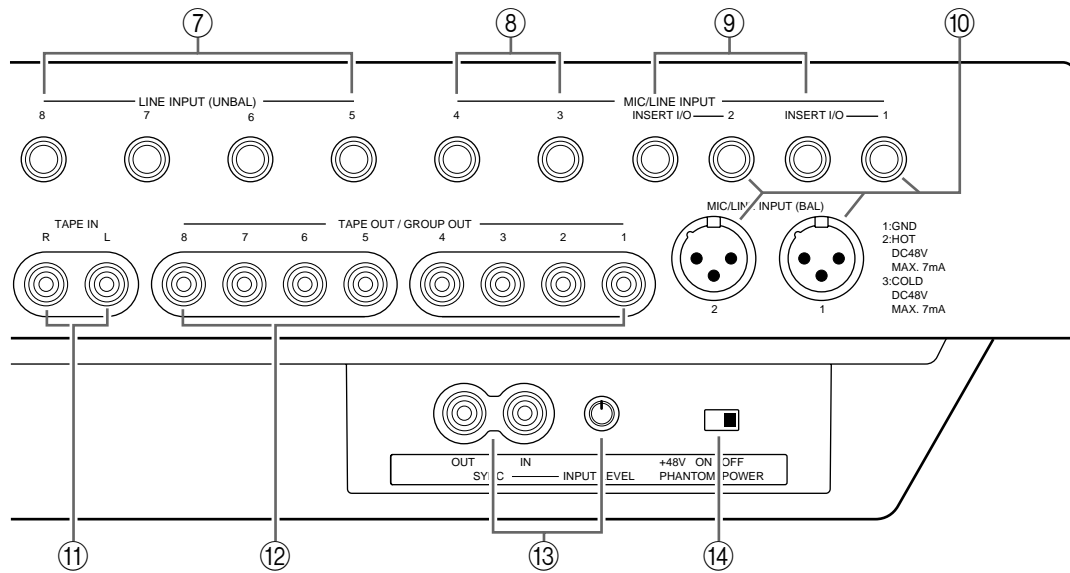

⑦ LINE INPUT (UNBAL) 5–8

These 1/4-inch phone jacks are used to connect electronic musical instruments and other line-level sound sources to the MT8XII.

⑧ MIC/LINE INPUTs 3 & 4

These 1/4-inch phone jacks are used to connect microphones, electronic musical instruments, and other line-level sound sources to the MT8XII.

⑨ INSERT I/O

These TRS phone jacks are used to connect signal processors for use with input channel 1 and input channel 2 exclusively. Typically, compressors, limiters, and noise gates are connected to this type of connection. A wiring diagram for an insert cable is provided on page 35.

⑩ MIC/LINE INPUTs 1 & 2

These inputs are used to connect balanced condenser microphones and balanced line-level sound sources to the MT8XII. Unbalanced sources can also be connected here. Each input features a XLR-type connector and TRS phone jack connector. The phone jack connector has priority. So you must remove any plugs from the phone jack connector to use the XLR-type connector. Phantom power is available on these inputs for use with condenser microphones. If you're not using condenser microphones with these inputs, keep the PHANTOM POWER ON/OFF switch set to OFF.

⑪ TAPE IN

These phono jacks are used to connect the outputs of a stereo master recorder to the MT8XII. The master recorder could be a DAT recorder, MiniDisc recorder, or cassette tape deck. Connect them to your master recorder's stereo outputs. To monitor the output of the stereo master recorder during mixdown, set the TAPE IN switch to TO MONITOR. To assign the TAPE IN signal to the stereo mix, set the TAPE IN switch to TO STEREO.

⑫ TAPE OUT/GROUP OUT

These phono jacks are used to send the tape playback signals or group signals to another mixer. This is useful when you use the MT8XII in conjunction with a sub mixer. Connect them to the line inputs on the other mixer. When the MT8XII is not recording or playing, the group signals

are output. Up to four group signals can be output simultaneously. A track must be selected for recording using the [REC SELECT] buttons for the group signal to be output. Group signals 1 through 4 can be output to GROUP OUTs 1 through 4 or GROUP OUTs 5 through 8. This is determined by the individual [REC SELECT] switches. For example, group signal 2 can be output to either GROUP OUT 2 or GROUP OUT 6, using REC SELECT button [2-6].

During playback, the eight tape signals are output.

⑬ **SYNC IN/OUT & INPUT LEVEL control**

These phono jacks are used to connect FSK and SMPTE synchronization signals. The INPUT LEVEL control is used to adjust the level of the incoming SYNC signal that's recorded onto Track 8.

⑭ **PHANTOM POWER ON/OFF switch**

This switch is used to turn on and off the phantom power for the XLR-type MIC/LINE (BAL) inputs on channels 1 and 2. Phantom power is used to power condenser microphones. It should be turned off when devices other than condenser microphones are connected to those inputs.

Front Connectors

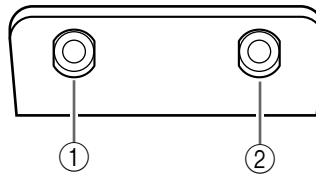

① **PHONES**

A pair of stereo headphones can be connected here for monitoring. The headphone signal is the same as the MONITOR OUT signal.

② **PUNCH I/O**

An optional footswitch, such as the Yamaha FC5, can be connected here for foot-controlled punch in/out.

3 The First Session

This chapter explains how to record and mix your first MT8XII session. If this is your first time with a multitrack recorder, we recommend that you start with this chapter and follow all the procedures closely. When you've completed this chapter, have a look at subsequent chapters, which explain more advanced MT8XII functions and require a basic knowledge of the MT8XII and multitrack recording techniques.

Connecting the Power Cord

1. **Connect the supplied power cord to the AC IN socket on the rear of the MT8XII.**
2. **Plug the other end of the power cord into a suitable AC wall outlet.**

Turning On the MT8XII

1. **Press the POWER switch at the rear of the MT8XII. The display lights up.**
To turn off the MT8XII, press the POWER switch again.

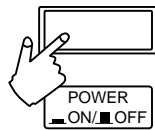

Loading a Tape

Before loading a tape, make sure the tape is not slack inside the cassette.

1. **Open the cassette compartment cover.**
2. **Load the cassette firmly into the compartment with the tape opening facing forward and the A side facing up. Make sure that it is seated correctly.**
The TAPE indicator appears on the display.
3. **Close the cassette compartment cover.**
If it's a new tape, fast forward and rewind it once to prevent binding, which may occur due to the tape being tightly wound during manufacturing.
4. **Press the [PLAY] button to start playback, and stop after about 20 seconds.**
It's best not to use the first and last 20 seconds of a tape, as the splice between the leader and tape can cause distortion.
5. **Press the [RESET] button to reset the tape counter to 00:00.**
The MT8XII is now ready for recording.

Quick-Start System

The following illustration shows the basic equipment necessary to start recording with the MT8XII.

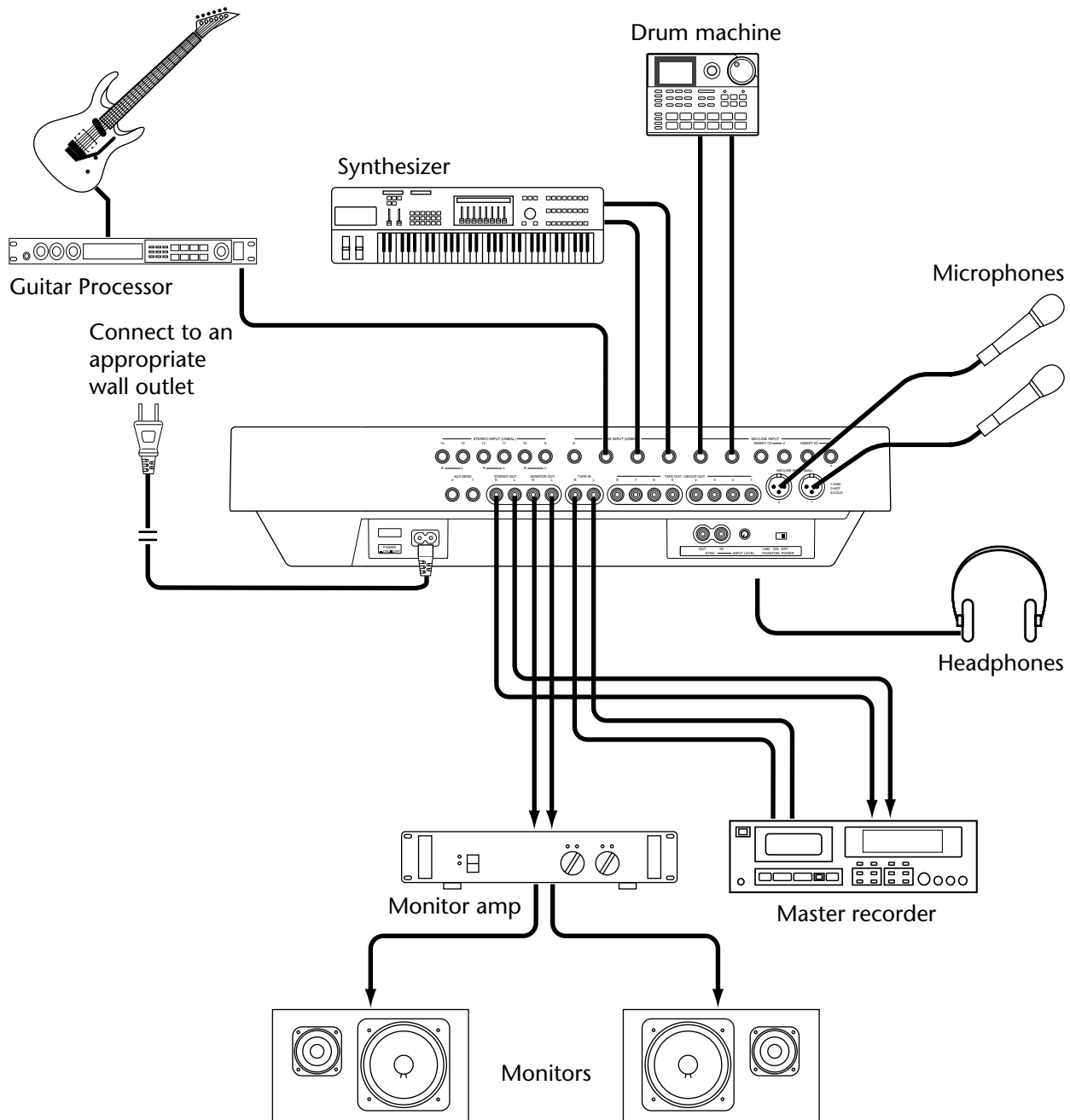

The microphones, synthesizer, guitar, and drum box are examples of the kind of sound sources that can be connected to the MT8XII. For monitoring, you can use either headphones or a monitor amp and speakers. Alternatively, you could use your hi-fi amp and speakers. The master recorder is required for mixdown.

Recording the First Track

1. Connect a sound source to MIC/LINE INPUT 1.
2. Set the [FLIP] switch on Input Channel 1 to the up position.
3. Adjust the GAIN control so that the SIGNAL indicator lights up most of the time, and the PEAK indicator lights up momentarily on the loudest sounds. It's important to set the GAIN control correctly. Too low a setting may result in a noisy recording. Too high a setting, on the other hand, may result in distortion.

Tip: If the level of the sound source varies greatly, making it difficult to find an optimum setting for the GAIN control, you can use an external compressor to even out the signal level.

4. Press the GROUP ASSIGN [1–2] switch on Input Channel 1.

This assigns the Channel 1 signal to Groups 1 and 2.







The following table show the relationship between Groups and Tracks.

Assigned to...		Destination Track
Group 1	→	Track 1 or Track 5
Group 2	→	Track 2 or Track 6
Group 3	→	Track 3 or Track 7
Group 4	→	Track 4 or Track 8

5. Turn the PAN control to L/ODD.

This sends the signal to just Group 1.

The following table show the relationship between the PAN control and Groups.

GROUP ASSIGN	PAN	Destination Group
		Group 1
		Group 3
		Group 2
		Group 4

6. Press the MONITOR SELECT [CUE] switch. This sets the monitor source to CUE.
7. Set the MONITOR LEVEL control midway.
8. Set the GROUP 1 MASTER level control midway.
9. Press REC SELECT button [1]. A circle flashes around track indicator 1.
10. Raise Channel 1 fader to the 7–8 mark. Track 1 meter shows the signal level.
11. Set the CUE LEVEL control on Input Channel 1 midway. You should now be able to hear the sound source. If you don't hear anything, recheck the preceding steps.
12. Adjust the GROUP 1 MASTER level control so that the loudest signals light

the +9 dB indicator.

When the dbx noise reduction system is not used, adjust the level control so that the loudest signals light the +3 dB indicator.

It's important to set the GROUP MASTER level control correctly. Too low a setting may result in a noisy recording. Too high a setting, on the other hand, may result in distortion.

13. Press the [REC/PAUSE] button.

The REC/PAUSE indicator lights up. The circle around the number of the selected track stops flashing and lights up continuously. The MT8XII waits in Record Pause mode.

The MT8XII is now ready to record. All you have to do to start recording is press the [PLAY] button. So make sure that your music source is ready to go. If you want to cancel Record Pause mode, press the [STOP] button.

14. Press the [PLAY] button to start recording.

Recording starts and the tape counter shows the recording time.

15. Press the [STOP] button to stop recording.

You've now recorded your first track.

Listening to the First Track

1. Press the [RTZ] button to rewind to 00:00.**2. Press the [PLAY] button to start playback.**

You should now be able to hear what was recorded on Track 1. Adjust the CUE LEVEL control as required. If you don't hear anything, recheck the preceding steps.

Overdubbing

Overdubbing is the technique used to record new sounds to empty tracks while listening to the sounds already recorded on other tracks. The following overdubbing procedure can be used to record on tracks 2 through 8.

1. On the input channel previously used for recording, set the fader to zero and set the GROUP ASSIGN switches to OFF.**2. Press the [REC SELECT] button of the track recorded previously to unselect it.**

The flashing circle around the track indicator disappears.

3. Press the [RTZ] button to rewind to 00:00.**4. Connect a sound source to another MIC/LINE INPUT.****5. Set the [FLIP] switch to the up position.****6. Adjust the GAIN control so that the SIGNAL indicator lights up most of the time, and the PEAK indicator lights up momentarily on the loudest sounds.**

For input channels 5 through 8, which don't have GAIN controls, use the output level controls on the source device to adjust the signal level.

7. Press a [GROUP ASSIGN] switch on the channel being used.
8. Use the PAN control to assign the signal to odd or even numbered group.
9. Set the GROUP MASTER level control midway.
10. Press the [REC SELECT] button of the track that you want to record.
A circle flashes around the number of the selected track and the meter shows the signal level.
11. Raise the Channel fader to the 7–8 mark.
The track meter shows the signal level.
12. Set the CUE LEVEL control on the corresponding input channel midway.
Note that this not the input channel sending the signal. It's the input channel whose number corresponds with that of the track being recorded. For example, to monitor Track 5, use the CUE LEVEL control on Input Channel 5. The CUE PAN control can be used to pan the signal.
You should now be able to hear the sound source. If you don't hear anything, recheck the preceding steps.
13. Adjust the GROUP MASTER level control so that the loudest signals light the +9 dB indicator.
When the dbx noise reduction system is not used, adjust the level control so that the loudest signals light the +3 dB indicator.
14. Press the [REC/PAUSE] button.
The REC/PAUSE indicator lights up. The circle around the number of the selected track stops flashing and lights up continuously. The MT8XII waits in Record Pause mode.

Note: You could press the [REHE] button instead to rehearse the overdub.
15. Press the [PLAY] button to start recording (or Rehearsal).
Recording (or Rehearsal) starts and the tape counter shows the recording time.
16. Use the CUE LEVEL controls corresponding to previously recorded tracks to balance the levels between what was previously recorded on other tracks and what you are recording now.
17. Press the [STOP] button to stop recording (or Rehearsal).
18. Press the [RTZ] button to rewind to 00:00.
19. Press the [PLAY] button to play back what you've recorded.
If you just rehearsed the overdub, there won't be anything to play back yet.
20. Use the CUE level controls to adjust the monitor level of each track.
Repeat this procedure until you've recorded all tracks. Then you're ready for mixdown.

Mixdown

Mixdown is the final technique in multitrack recording. Here you mix the sounds from all eight tracks, with EQ and effects, into a balanced stereo mix and record it to a stereo master recorder, such as a DAT, MiniDisc, or cassette tape machine.

1. **Make sure that all [GROUP ASSIGN] switches are off, including the MONITOR SELECT [CUE] switch.**
2. **Set the [FLIP] switch on each input channel to the down position.**
3. **Set the PAN control on each input channel to its center position.**
4. **Set the fader on each input channel and the STEREO fader to the 7–8 mark.**
5. **Press the MONITOR SELECT [STEREO] switch and set the MONITOR LEVEL control midway.**
6. **Press the [RTZ] button to rewind to 00:00.**
7. **Press the [PLAY] button to start playback.**
You should now be able to hear all tracks playback. If you don't hear anything, recheck the preceding steps.
8. **Mix and refine your music as follows:**
 - Balance Levels**—Use the input channel faders to balance the levels of the tracks.
 - Pan**—Use the PAN controls to position sounds between the left and right speakers.
 - EQ**—Use the EQ to shape the tone of each track.
 - Apply Effects**—Use the AUX SENDs to patch in external effects processors. See *Using Effects* on page 33 for more information.
9. **Record the final mix to your stereo master recorder.**
That's it! You've completed your first session with the MT8XII.

Multi-Source Mixing

In addition to the eight tape tracks, you can also connect external sound sources to the MIC/LINE inputs and mix up to eight more sound sources with the tape tracks. These extra sound sources are mixed using the CUE LEVEL and PAN controls. The [CUE MIX TO STEREO] button makes this possible. When this button is in the ON position, the CUE bus signals are not fed to the monitor section. Instead they are fed to the Stereo bus for mixing.

In combination with the eight tape tracks, ST INs, and TAPE IN, this means that up to 20 inputs are available for mixdown. Typically, these extra sound sources could be MIDI tone generators, synthesizers, samplers, etc., that are being controlled by a MIDI sequencer.

The following procedure is similar to the previous mixdown procedure except that it explains how to use the CUE controls to mix the tape signals and MIC/LINE signals.

1. **Make sure that all [GROUP ASSIGN] switches are off, including the MONITOR SELECT [CUE] switch.**
2. **Use the [FLIP] switch on each input channel to feed the tape and MIC/LINE signals to the input channel and CUE controls.**
With the [FLIP] switch in the up position, the MIC/LINE input signal is fed to the input channel and the tape signal is fed to the CUE controls. With the [FLIP] switch in the down position, however, this is reversed: the MIC/LINE input signal is fed to the CUE controls and the tape signal is fed to the input channel. As the CUE controls consist of just level and pan, signals that require EQ and effects should be fed to the input channel.
3. **Set the PAN and CUE PAN controls on each input channel to their center positions.**
4. **Set the input channel and STEREO faders to the 7–8 mark, and set the CUE LEVEL controls midway.**
5. **Set the [CUE MIX TO STEREO] button to ON.**
6. **Press the MONITOR SELECT [STEREO] switch and set the MONITOR LEVEL control midway.**
7. **Press the [RTZ] button to rewind to 00:00.**
8. **Press the [PLAY] button to start playback.**
Playback starts. You can now mix the tape and MIC/LINE signals.
9. **Mix and refine your music as follows:**
 - Balance Levels**—Use the input channel faders and CUE LEVEL controls to balance the levels of the tape and MIC/LINE signals.
 - Pan**—Use the input channel PAN controls and the CUE PAN controls to pan signals.
 - EQ**—Use the EQ to shape the tone of the signals fed to the input channels.
 - Apply Effects**—Use the AUX SENDs to patch in external effects processors. See *Using Effects* on page 33 for more information.

You cannot use EQ and effects with the signals that are controlled using the CUE controls. You could, however, connect an external equalizer or effects processor between the sound source and the MT8XII input. If you are using the MIC/LINE inputs to connect MIDI-controlled instruments, such as tone generators, synthesizers, and samplers, you can use the EQ and effects functions built into these devices.
10. **Record the final mix to your stereo master recorder.**

An Overview of Multitrack Recording

This section describes the fundamental principles of multitrack recording.

Basic Multitracking

Monitoring—This is the process of listening to a sound as it's being recorded or listening to recorded sounds as new sounds are recorded to other tracks. See *About Monitoring* on page 21 for more information.

Recording the First Track—The first track to be recorded is typically the drum track. A drum track that starts before other instruments makes a good timing and count-in reference. If your song starts with several instruments on the first bar, you may find it helpful to record a temporary count-in on another track, which can be erased later. See *Recording the First Track* on page 15 for more information.

Overdubbing—This is the technique of recording new sounds to empty tracks while listening to the sounds that you've already recorded on the other tracks. Essentially, songs are recorded track-by-track. This technique is used for most modern studio recording. See *Overdubbing* on page 16 for more information.

Mixdown—This is the final technique in multitrack recording. Here you mix the sounds from all eight tracks, with EQ and effects, into a balanced stereo mix and record it to a stereo master recorder, such as a DAT, MiniDisc, or cassette tape machine. The MT8XII's [FLIP] button allows you to mix the eight track signals with eight signals from other sound sources (e.g., from MIDI-controlled instruments). In combination with the ST INs and TAPE IN, this provides up to 20 sound sources during mixdown. See *Mixdown* on page 18 for more information.

Advanced Multitracking

One-Take Recording—With this technique, up to four tracks are recorded in one take. This is useful for live recording and recording bands that like to record with all members playing together. Punch in/out and ping-pong techniques can be used after the one-take recording to add and correct sections. See *One-Take Recording* on page 44 for more information.

Punch In/Out—This technique allows you to rerecord specific sections of a track. It's often used to rerecord a not so perfect guitar solo or vocal phrase. Punch in/out can be rehearsed before actually recording to tape. Punch in/out on the MT8XII can be performed manually or automatically, which is useful when you are playing or singing and operating the MT8XII all at the same time. See *Manual Punch In/Out* on page 23 for more information.

Ping-Pong—This technique allows you to mix and record several tracks onto another track. This is often used to free up tracks for more recording. So although the MT8XII is an eight-track recorder, you can actually record more than eight tracks using the ping-pong technique. You can also combine ping-pong with overdub recording. For example, Tracks 1, 2, and 3 are mixed and recorded onto Track 5 along with a new signal coming from Input Channel 4. Ping-pong can be rehearsed before actually recording to tape. See *Ping-Pong Recording* on page 29 for more information.

Synchronization—This technique enables the MT8XII and a MIDI sequencer to work together as a unified recording tool: the MT8XII for acoustic sounds and the MIDI sequencer for MIDI instrument sounds. See *The MT8XII & MIDI* on page 40 for more information.

About Monitoring

The MT8XII features a flexible monitoring system, allowing you to monitor signals at various points. You can monitor sounds through a pair of stereo headphones connected to the PHONES jack, or through a monitor amplifier and speakers connected to the MONITOR OUT jacks. The MONITOR SELECT switches are used to select the monitor source, and the MONITOR LEVEL control is used to adjust the level.

GROUP—These switches select the Group buses as the monitor source. This allows you to monitor signals that are assigned from input channels or ST inputs to groups for recording. Use these switches to monitor what will be recorded. For example, if you're recording the sounds from three input channels to one track simultaneously, you'll need to listen to a mix of the three sounds in order to balance the levels correctly. You can do this using the GROUP switches.

When only the [1–3] or [2–4] MONITOR SELECT GROUP switch is pressed, the monitor signal is set as mono. This ensures that the signal being monitored appears in both the left and right monitor speakers. So even when you monitor a single group signal, it will be heard through both speakers. When both the [1–3] and [2–4] MONITOR SELECT GROUP switches are pressed, however, the monitor signal is set as stereo. So you can monitor stereo signals on Groups 1 and 2 or Groups 3 and 4.

STEREO—This switch selects the Stereo bus as the monitor source. This allows you to monitor the STEREO OUT signals and is typically used during mixdown. It can also be used to monitor signals that are not going to be recorded by the MT8XII, such as a MIDI tone generator that is controlled by a MIDI sequencer. In this case, the tone generator is only monitored while other sounds are recorded on the MT8XII. Then for the final mixdown, the tone generator sounds are mixed with the sounds recorded on the MT8XII and mixed down to a stereo master recorder.

CUE—This switch selects the CUE bus as the monitor source. The CUE bus signal from each input channel is determined by the [FLIP] switch. When the [FLIP] switch is in the up position, the tape signal is fed to the input channels CUE controls and onto the CUE bus (the MIC/LINE signal is fed to the channel fader and controls). When the [FLIP] switch is in the down position, the MIC/LINE signal is fed to the input channels CUE controls and onto the CUE bus (the tape signal is fed to the channel fader and controls).

When the tape signal is monitored using CUE, the actual sound source changes when the MT8XII starts recording or rehearsing. During normal playback, the sound recorded on tape is monitored. Obviously, if nothing is recorded, there's nothing to monitor. When either record or rehearse is started, however, the source is changed to the signal being recorded. The application of this may not appear very obvious at the moment, but all will become clear in the punch in/out and ping-pong recording sections.

Note: Although you can monitor GROUP, STEREO, and CUE all at the same time, there is a possibility that you'll monitor the same signal from two different points in the signal flow. At first, you may find it less confusing to select just one monitor source at a time.

4 Punch In/Out Recording

This chapter explains the MT8XII punch in/out recording techniques.

Punch In/Out

Punch in/out techniques allows you to rerecord specific sections of a track. This can be used to correct mistakes or record something new into silent sections of a track. The MT8XII allows you to perform punch in/out manually or automatically. Manual punch in/out can be performed using a footswitch, leaving your hands free. If you're operating the MT8XII and playing or singing the part to be recorded, you'll find it much easier to use the Auto Punch In/Out function, which performs the punch in/out automatically. See *Auto Punch In/Out* on page 26 for more information.

The following illustration shows the various points of the punch in/out process.

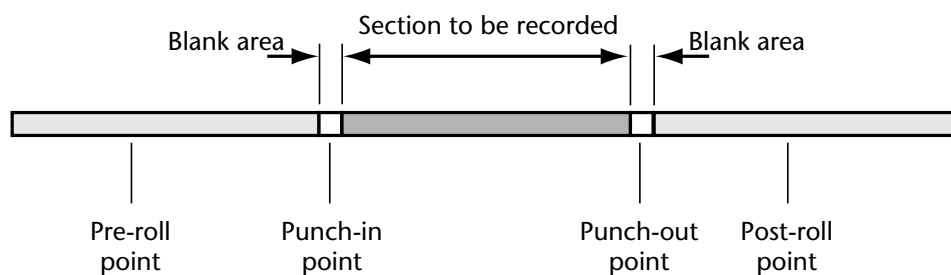

Pre-roll point—the point at which the Auto Punch In/Out sequence starts.

Punch-in point—the point at which recording starts.

Punch-out point—the point at which recording stops.

Post-roll point—a point approximately five seconds after the punch out point.

The pre-roll and post-roll points are used only with the Auto Punch In/Out function.

In the above illustration, the punch-in and punch-out points are shown in the middle of blank areas. These blank areas indicate that punch in and punch out are not instantaneous. This is because the erase head is located before the record-play head. About half a second (0.3 sec) of tape is erased before the actual punch-in point and after the punch-out point. For this reason, always chose a punch-in point that is at least half a second after any existing material, and a punch-out point that is at least half a second before any existing material. Failure to do so may result in the “tail” or “top” of existing material being erased.

Manual Punch In/Out

Manual punch in/out can be performed in three different ways: 1) using the [REC/PAUSE] button. 2) using the individual [REC SELECT] buttons. 3) using an optional footswitch. The Rehearsal function can be used with all three methods.

Using the REC/PAUSE Button

1. **Locate to a position before the point at which you want to punch in.**
2. **Press the [REC SELECT] button of the track that you want to record.**
A circle flashes around the corresponding track indicator.
3. **Press the [PLAY] button to start playback.**
Playback starts and the PLAY indicator lights up.
4. **At the point where you want to punch in, press the [REC/PAUSE] button.**
Recording starts. The REC/PAUSE indicator lights up. The circle around the track indicator stops flashing and lights up continuously.

If you're monitoring the track via CUE (i.e., [FLIP] switch in the up position), you'll hear the existing sound playback until the [REC/PAUSE] button is pressed. After which you'll hear the new sound that's being recorded.

Instead of pressing the [REC/PAUSE] button you could have pressed the [REHE] button to engage Rehearse mode. Rehearse allows you to have a dry run before actually recording. In Rehearse mode, the REHE indicator lights up, not the REC/PAUSE indicator.

5. **At the point where you want to punch out, press the [PLAY] button.**
Recording stops. The REC indicator goes off. The circle around the track indicator flashes.
Through the CUE monitor (i.e., [FLIP] switch in the up position) you'll hear the existing sound playback.
6. **Press the [STOP] button to stop playback.**
The following illustration shows how punch in/out works with the [REC/PAUSE] button.

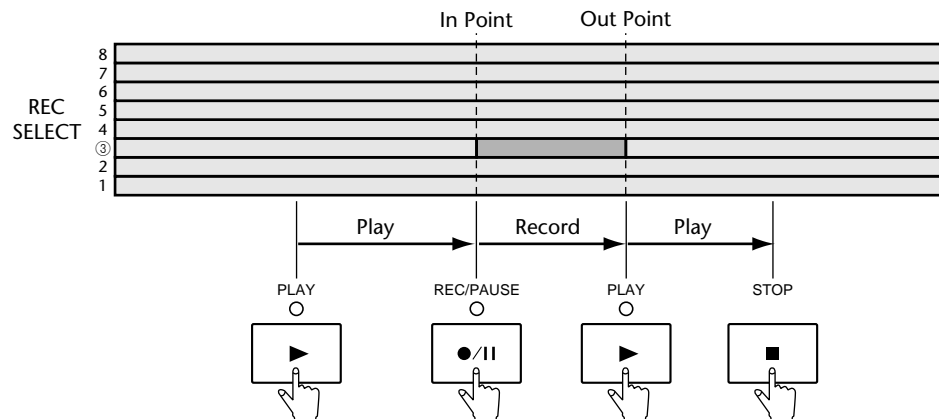

Using the REC SELECT buttons

1. **Locate to a position before the point at which you want to punch in.**
2. **Make sure that all track indicators are off (i.e., no tracks selected).**
3. **Press the [REC/PAUSE] button.**

The REC/PAUSE indicator flashes quickly, indicating Record Pause mode is engaged.

Instead of pressing the [REC/PAUSE] button you could have pressed the [REHE] button to engage Rehearse Pause mode. Rehearse allows you to have a dry run before actually recording. The rest of this procedure can be used with the Rehearsal function. Instead of the REC/PAUSE indicator, however, the REHE indicator is used.

4. **Press the [PLAY] button to start playback.**

Playback starts and the PLAY indicator lights up. The REC/PAUSE indicators continue to flash, indicating Play Record Wait mode.

5. **At the point where you want to punch in, press a [REC SELECT] button.**

Recording starts. The REC/PAUSE indicator stop flashing and light up continuously. A circle appears around the corresponding track indicator.

If you're monitoring the track via CUE (i.e., [FLIP] switch in the up position), you'll hear the existing sounds playback until the [REC SELECT] button is pressed. After which you'll hear the new sound that's being recorded.

You can punch in more than one track using this technique. However, do not press more than one [REC SELECT] button simultaneously. Press them one after another.

6. **At the point where you want to punch out, press the [PLAY] button.**

Recording stops. The REC/PAUSE indicator goes off. The circle around the track indicator flashes.

Through the CUE monitor (i.e., [FLIP] switch in the up position) you'll hear the existing sounds playback.

Instead of pressing the [PLAY] button you could have pressed the [REC SELECT] button to punch out. In this case, the MT8XII remains in Play Record Wait mode, so you can punch in again using the [REC SELECT] buttons.

7. **Press the [STOP] button to stop playback.**

The following illustration shows how punch in/out works with the [REC SELECT] buttons.

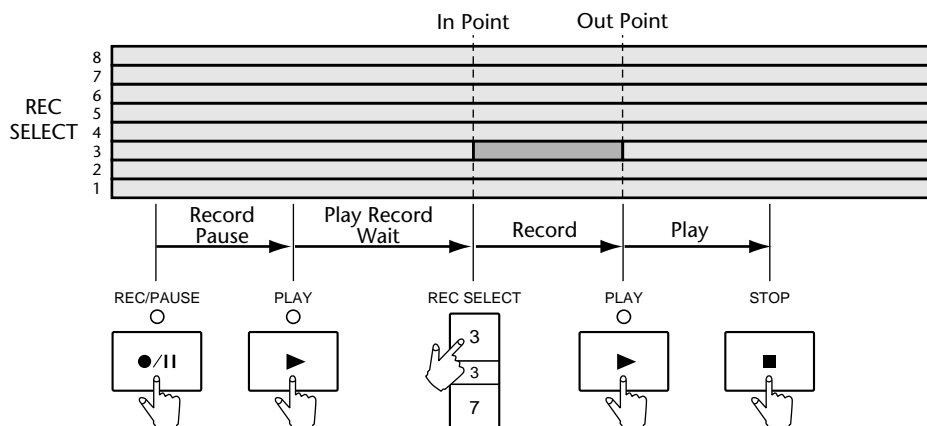

Using a Footswitch

1. **Connect an optional footswitch to the PUNCH I/O jack.**
2. **Locate to a position before the point at which you want to punch in.**
3. **Press the [REC SELECT] button of the track that you want to record.**
A circle flashes around the corresponding track indicator.
4. **Press the [REC/PAUSE] button.**
The REC/PAUSE indicator flashes, indicating Record Pause mode is engaged.
5. **Press the footswitch to start playback.**
Playback starts and the PLAY indicator lights up. The REC/PAUSE indicator continues to flash.
6. **At the point where you want to punch in, press the footswitch again.**
Recording starts. The REC/PAUSE indicator lights up. The circle around the track indicator stops flashing and lights up continuously.

If you're monitoring the track via CUE (i.e., [FLIP] switch in the up position), you'll hear the existing sounds playback until the footswitch is pressed. After which you'll hear the new sound that's being recorded.
7. **At the point where you want to punch out, press the footswitch again.**
Recording stops. The REC/PAUSE indicator goes off. The circle around the track indicator flashes.

Through the CUE monitor (i.e., [FLIP] switch in the up position) you'll hear the existing sounds playback.
8. **Press the [STOP] button to finish.**
The following illustration shows how punch in/out works with a footswitch.

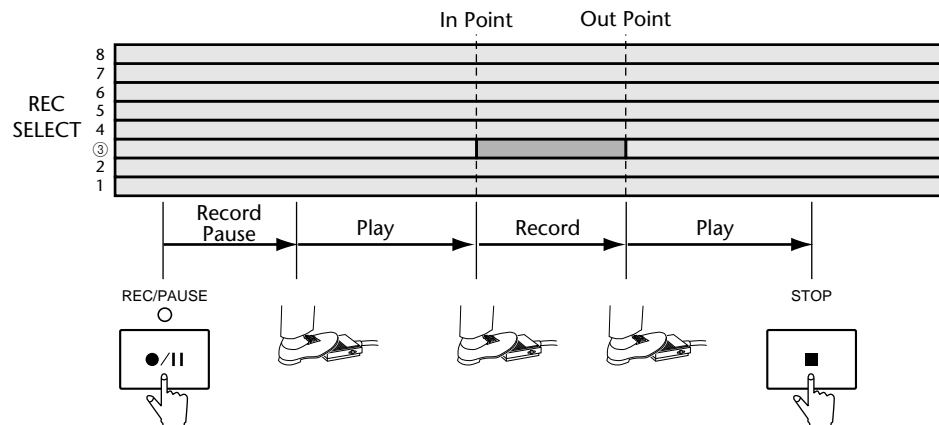

Auto Punch In/Out

The Auto Punch In/Out function automates the punch in/out procedure, allowing you to concentrate on your playing or singing. You can rehearse the punch in/out repeatedly until you are ready to perform the punch in/out for real. An optional footswitch can be connected to the PUNCH I/O jack on the MT8XII for use with the Auto Punch In/Out function.

Setting the Punch In/Out Points

1. **Locate to a position before the point at which you want to punch in.**
2. **Press the [AUTO PUNCH I/O] button.**
This sets the pre-roll point. The AUTO PUNCH I/O and REHE indicators flash.
3. **Press the [PLAY] button (or footswitch) to start playback.**
Playback starts and the PLAY indicator lights up. The REHE and IN indicators flash and the REC/PAUSE indicator flashes quickly.
4. **At the point where you want to set the punch-in point, press the [REC/PAUSE] button (or footswitch).**
The IN indicator stops flashing and lights up continuously, indicating that the punch-in point has been set. The REHE and OUT indicators flash. The PLAY indicator flashes quickly. The REC/PAUSE indicator goes off.
5. **At the point where you want to set the punch-out point, press the [PLAY] button (or footswitch).**
The OUT indicator and PLAY indicator stop flashing and light up continuously, indicating that the punch-out point has been set.

Playback continues for 5 seconds after the [PLAY] button was pressed. Then, the tape rewinds back to the pre-roll point, the IN and OUT indicators disappear from the display, and the REHE indicator flashes quickly, indicating that the punch-in and punch-out points have been set.

If you want to set the punch-in and punch-out points again, press the [CLEAR] button, and then go back to Step 3.

If you want to set the pre-roll point again, press the [AUTO PUNCH I/O] button to turn off the Auto Punch In/Out function, and then go back to Step 1.

The following illustration shows how the punch-in and punch-out points are set.

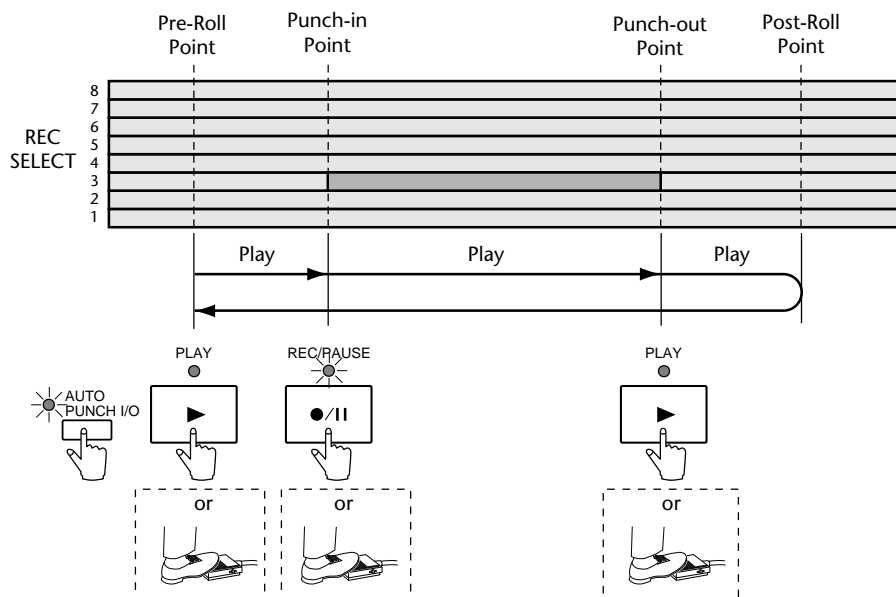

Rehearsing Auto Punch

Once the punch-in and punch-out points have been set, you can rehearse the punch in/out.

1. Press the [REC SELECT] button of the track that you want to record.

A circle flashes around the corresponding track indicator.

If you're monitoring the track via CUE (i.e., [FLIP] switch in the up position), you'll hear the signal that is assigned to the selected track.

If you want to rehearse the Auto Punch In/Out repeatedly, press the [REPEAT] button. The REPEAT indicator flashes on the display.

2. Press the [PLAY] button (or footswitch) to start the Auto Punch In/Out sequence.

Playback starts. The PLAY indicator lights up and the REHE indicator flashes, indicating Play Rehearse Wait mode.

At the specified punch-in point, punch in occurs (i.e., rehearsal starts). The REHE indicators stop flashing and lights up continuously. The IN indicator appears on the display.

If you're monitoring the track via CUE (i.e., [FLIP] switch in the up position), you'll hear the existing sounds playback until the punch-in point. After which you'll hear the new sound that's being recorded.

At the specified punch-out point, punch out occurs (i.e., rehearsal stops). The REHE indicator goes out and the OUT indicator appears on the display.

Playback continues up to the post-roll point. Then the tape rewinds to the pre-roll point, and the MT8XII waits in Auto Punch Rehearse Standby mode. You can press the [PLAY] button again for another rehearsal or move on to the next section to perform the Auto Punch In/Out for real.

If you pressed the [REPEAT] button in Step 1, the MT8XII will rehearse the Auto Punch In/Out repeatedly until you press the [STOP] button. Pressing the [STOP] button at anytime during the punch in/out sequence stops the tape, and rewinds back to the pre-roll point.

The following illustration shows the Auto Punch Rehearse sequence.

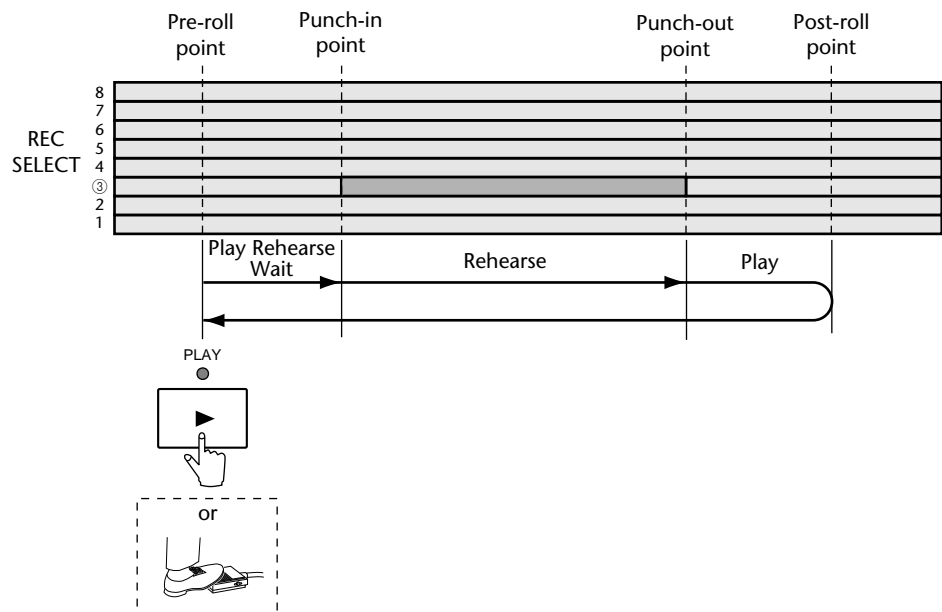

Performing Auto Punch for Real

This section continues on from the *Rehearsing Auto Punch* section.

1. Press the [REC/PAUSE] button.

The REC/PAUSE indicator flashes. This is Auto Punch Record Standby mode.

2. Press the [PLAY] button (or footswitch) to start the Auto Punch In/Out sequence.

Playback starts and the PLAY indicator lights up. The REC/PAUSE indicator continues to flash, indicating Play Record Wait mode.

At the specified punch-in point, punch in occurs (i.e., recording starts). The REC/PAUSE indicator stops flashing and lights up continuously. The IN indicator appears on the display.

If you're monitoring the track via CUE (i.e., [FLIP] switch in the up position), you'll hear the existing sounds playback until the punch-in point. After which you'll hear the new sound that's being recorded.

At the specified punch-out point, punch out occurs (i.e., recording stops). The REC/PAUSE indicator goes out and the OUT indicator appears on the display.

Playback continues up to the post-roll point. Then the tape rewinds back to the pre-roll point. Press the [PLAY] button to audition the punch in/out.

The following illustration shows the Auto Punch Record sequence.

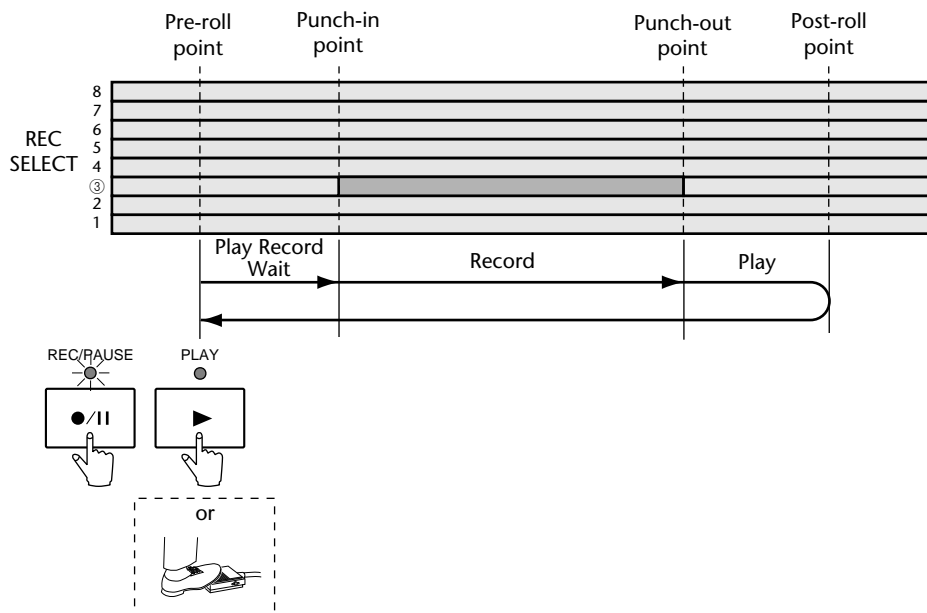

5 Ping-Pong Recording

The ping-pong recording technique (also known as bounce down) is used to free up tracks for further recording. This is accomplished by bouncing down (i.e., mixing and recording) one or two existing tracks to an unused track. Those tracks are then used for further recording. Although the MT8XII is an eight-track recorder, effectively you can record more than eight tracks using this technique. The only drawback is that once several tracks have been bounced, you cannot adjust the individual sounds. You can, however, balance the levels and apply EQ and effects during the actual ping-pong operation. The following illustration shows the ping-pong technique.

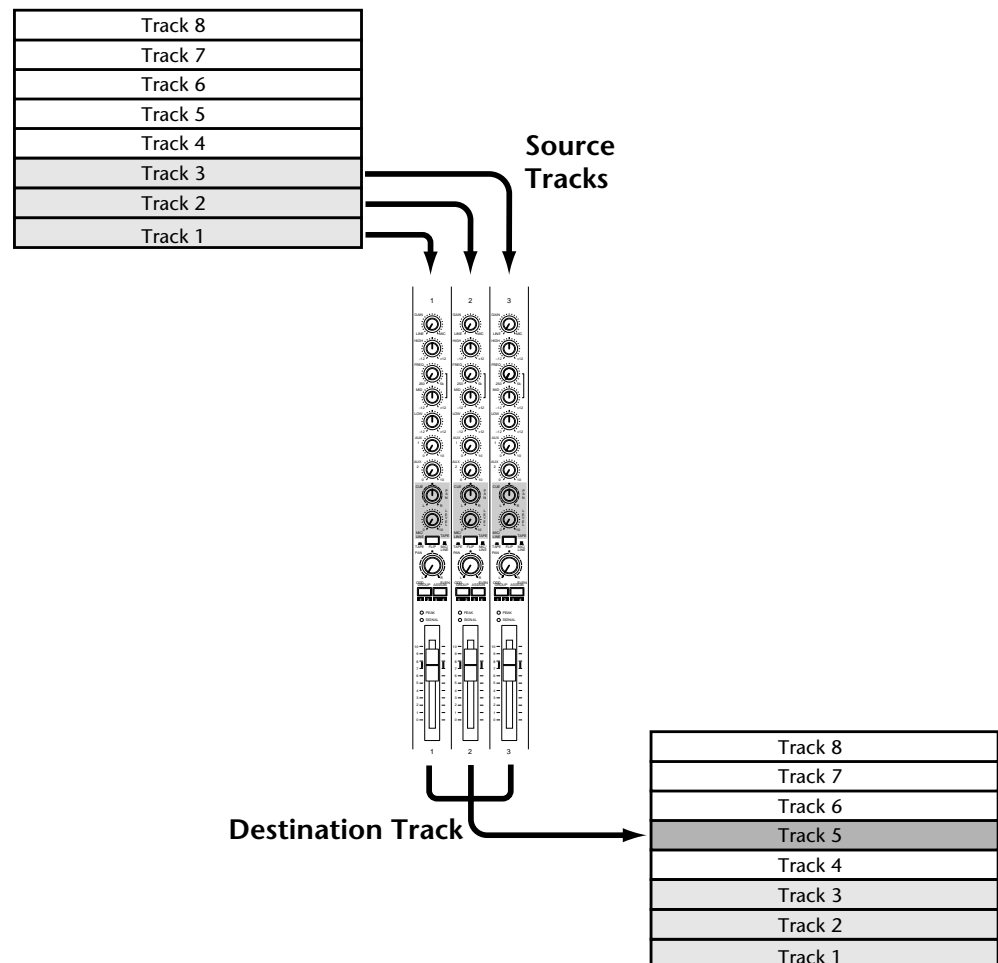

Preparing for Ping-Pong

1. **Press the [RTZ] button to rewind to the beginning of the song.**
2. **Set the [FLIP] switches on the source track channels to the down position.**
This sets the tape signal as the source for the channels.
3. **Set the faders on the source channels to the 7–8 mark.**
4. **Use the ASSIGN switches and PAN controls on the source track channels to assign the signals to the destination track.**
See *Recording the First Track* on page 15 for information about using the ASSIGN switches and PAN controls to assign signals to tracks.
5. **Press the [REC SELECT] button of the destination track.**
A circle flashes around the corresponding track indicator.
6. **Press the MONITOR SELECT [GROUP] switch for the destination track.**
This sets the monitor source to the destination track.
7. **Set the MONITOR LEVEL control as required.**

Rehearsing the Ping-Pong

8. **Press the [REHE] button.**
The REHE indicator lights up and the circle flashes around the corresponding track indicator stops flashing and lights up continuously.
9. **Press the [PLAY] button to start the rehearsal.**
The rehearsal starts and the PLAY indicator lights up.
You should now be able to hear the source tracks combined.
10. **Use the faders to balance the source track levels and apply EQ as required.**
Repeat the ping-pong rehearsal until you are satisfied with the combined sound.

Performing the Ping-Pong for Real

11. **Press the [RTZ] button to rewind to the beginning of the song.**
12. **Press the [REC/PAUSE] button.**
The REC/PAUSE indicator lights up and the circle flashes around the corresponding track indicator stops flashing and lights up continuously.
13. **Press the [PLAY] button to start recording.**
Recording starts and the PLAY indicator lights up.
14. **When the song has finished, press the [STOP] button.**

Checking the Ping-Pong Operation

15. Press the [RTZ] button to rewind to the beginning of the song.
16. Press the MONITOR SELECT [GROUP] switch that you pressed previously to monitor the destination track.
17. Press the MONITOR SELECT [CUE] switch.
18. On the input channel that corresponds to the destination track (e.g., input channel 5 for track 5), set the [FLIP] switch to the up position.
19. Set the CUE LEVEL control corresponding to the destination track to mid-way.
20. Press the [PLAY] button to start playback.
You should now be able to hear the new combined track.

Ping-Pong Notes

There are several things to be aware of when using the ping-pong technique.

- Do not try and bounce a track to itself. That is, make sure that the destination track is not one of the source tracks. Otherwise, an unpleasant oscillation noise may be produced.
- Repeated ping-pong operations do affect the sound quality. Try to keep ping-pong operations to a minimum.
- Avoid bouncing tracks to adjacent tracks on the same half of the record-play head. It's okay to bounce from Track 4 to Track 5 because they are on different halves of the head, as shown here. The illustration below shows three ping-pong combinations to avoid and three that are okay.

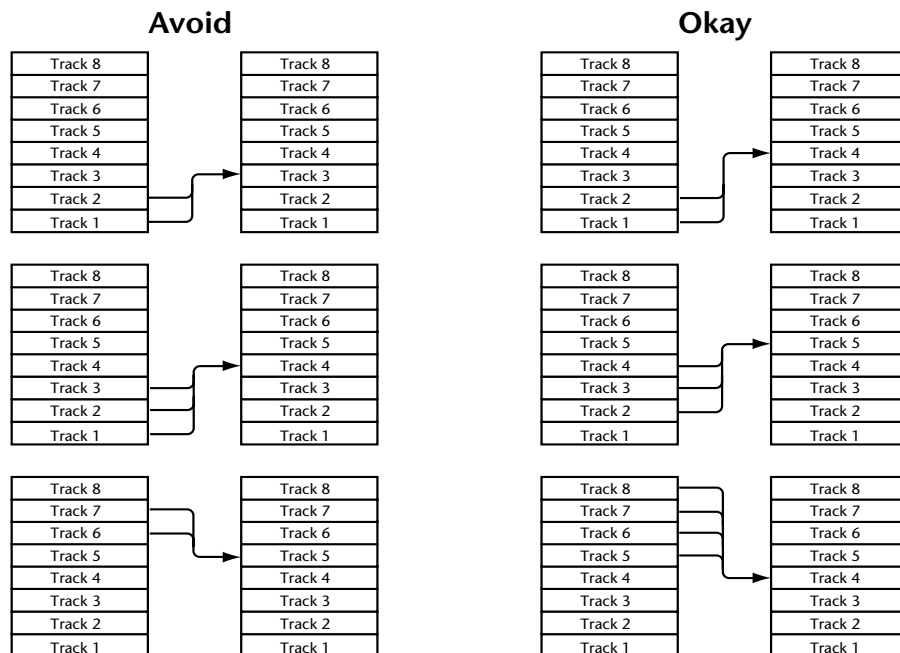
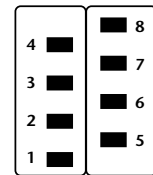

Ping-Pong with Overdub

The ping-pong technique can be combined with overdub recording. This allows you to bounce down tracks and record a new sound source simultaneously. In the following illustration, for example, Tracks 1, 2, and 3 are bounced to Track 4 along with a new signal coming from Input Channel 4.

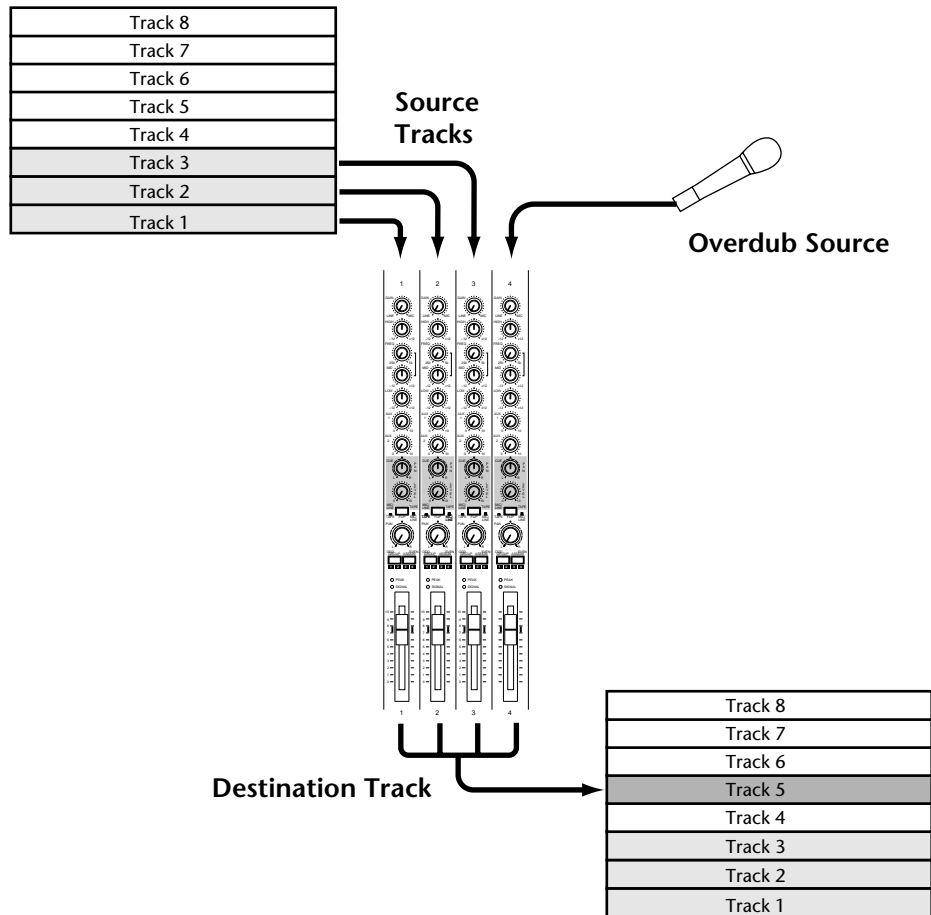

1. Connect a sound source to an unused input channel (i.e., one that's not used with an existing source track). Input channel 4 is used in the example above.
2. Set the GAIN control as appropriate.
3. On input channels 1, 2, and 3, set the [FLIP] switch to the down position.
4. On input channels 4 and 5, set the [FLIP] switch to the up position.
5. Set the fader to the 7–8 mark.
6. Use the ASSIGN switches and PAN control to assign the signal to the destination track.
7. Continue with *Preparing for Ping-Pong* on page 30.
During rehearsal, balance the level of the new source with the existing tracks.

6 Using Effects

The AUX SENDs allow you to connect external effects processors and apply effects to MT8XII signals. Effects can be applied when recording tracks, using ping-pong, or during mixdown. Typically, reverb and delay type effects, which are often applied to several sounds in a mix, are used with this type of connection.

The input channel AUX controls are used to send signals to the effects processors. The processed signal is returned to the MT8XII through a ST INPUT and mixed with the original, unprocessed signal to achieve a balance before being recorded to an MT8XII track, or the master recorder during mixdown.

The signal for the AUX control is sourced post-fader. So as well as turn up the AUX control, you must also raise the fader. This has the advantage that the level of the processed signal from the external effects processor is controlled in unison with the unprocessed signal that is controlled by the fader. So when you fade out a channel, the signal from the effects processor fades too.

1. **Connect an MT8XII AUX SEND jack to the external effects processor's input.**
2. **Connect the processor's stereo outputs to an MT8XII ST INPUT.**

The left ST INPUT signal is fed to the Left Stereo bus and Groups 1 and 3. The right ST INPUT signal is fed to the Right Stereo bus and Groups 2 and 4. So if you want to send the processed signal to both the left and right channels during mixdown, or both odd and even groups when recording tracks, you must connect to both jacks of a ST INPUT (i.e., L and R).

The following illustration shows how to connect an external effects processor to the MT8XII. Other equipment has been removed for clarity.

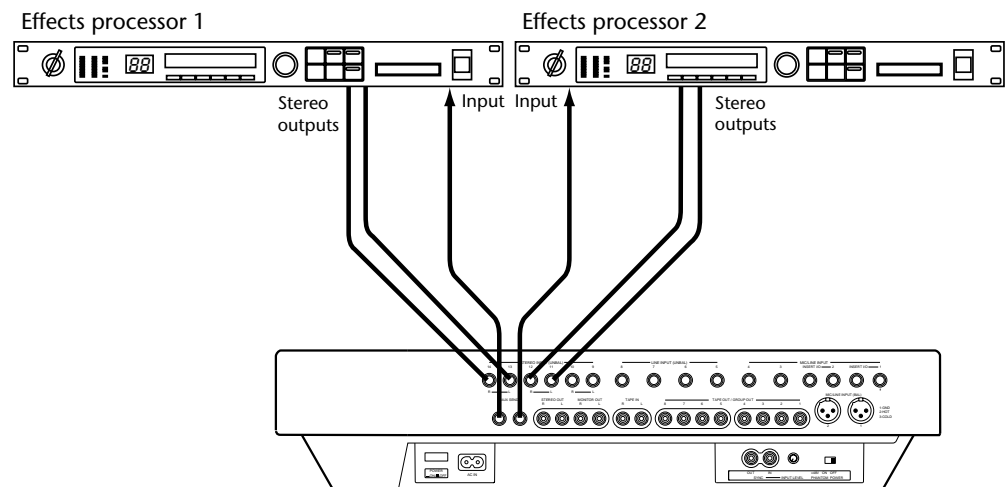

Applying Effects at Mixdown

1. **To send a signal to an effects processor, set the input channel fader to the 7–8 mark and turn up an AUX control.**

The input channel signal is sent to the effects processor and the Stereo bus.

2. **Set the effects processor as required.**

3. **To mix the processed signal back into the stereo mix, turn up the ST INPUT level control.**

Use the ST INPUT level control to balance the processed signal with the dry, unprocessed signal that is coming directly from the input channel. Use the input channel fader to adjust the level of the unprocessed signal. Set the MONITOR SELECT to GROUP to monitor both signals.

You can apply the same effect to other channels using the corresponding AUX controls.

Applying Effects when Recording

1. **To send an input channel signal to an effects processor, set the [FLIP] switch to the up position, the fader to the 7–8 mark, and turn up an AUX control.**

The input channel signal is sent to the effects processor.

2. **Use the GROUP ASSIGN switches to assign the input channel signal to a group.**

The input channel signal is sent to the specified group.

3. **Set the effects processor as required.**

4. **To send the processed signal to the track, press the ST INPUT GROUP ASSIGN switch corresponding to the GROUP ASSIGN switch pressed in Step 2, and then turn up the ST INPUT level control.**

Use the ST INPUT level control to balance the processed signal with the unprocessed signal that is coming directly from the input channel. Use the input channel fader to adjust the level of the unprocessed signal. Set the MONITOR SELECT to GROUP to monitor both signals.

With the balance set, you're ready to record.

Applying Effects with Ping-Pong

1. **To send an input channel signal to an effects processor, set the [FLIP] switch to the up position, the fader to the 7–8 mark, and turn up an AUX control.**

The input channel signal is sent to the effects processor.

2. **Use the GROUP ASSIGN switches to assign the input channel signal to the destination group.**

The input channel signal is sent to the destination group.

3. **Set the effects processor as required.**

4. **To send the processed signal to the track, press the ST INPUT GROUP ASSIGN switch corresponding to the GROUP ASSIGN switch pressed in Step 2, and then turn up the ST INPUT level control.**

Use the ST INPUT level control to balance the processed signal with the unprocessed signal that is coming directly from the input channel. Use the input channel fader to adjust the level of the unprocessed signal. Set the MONITOR SELECT to GROUP to monitor both signals.

With the balance set, you're ready to perform the ping-pong operation.

Patching In Signal Processors

Input channels 1 and 2 feature INSERT I/O jacks. These make it easy to patch external signal processors directly into these two channels. Typically, compressors, limiters, and noise gates are connected to this type of connection. Reverb, delay, and other effects processors can be used too.

The INSERT I/O connections, which use TRS (Tip, Ring, Sleeve) phone jacks, are two-way connections, with the tip carrying the output signal from the MT8XII to the external processor and the ring carrying the output signal from the external processor back into the MT8XII. You need special insert cables to do this. A wiring diagram for an insert cable is shown below.

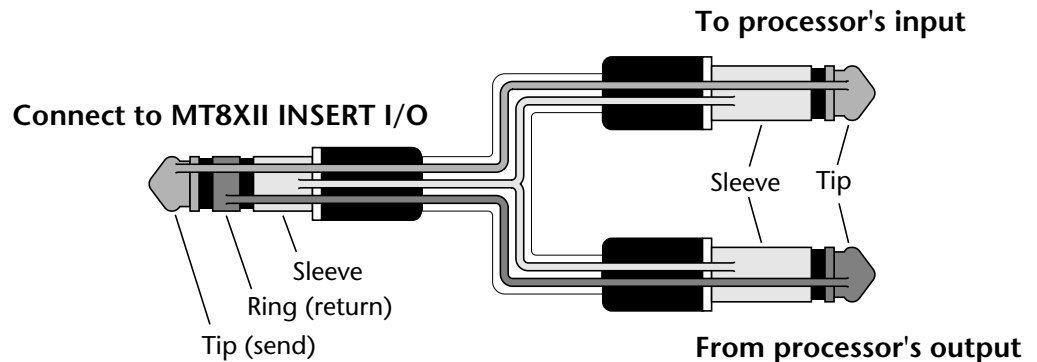

The following illustration shows how to connect an external processor to the MT8XII INSERTs. Other equipment has been removed for clarity.

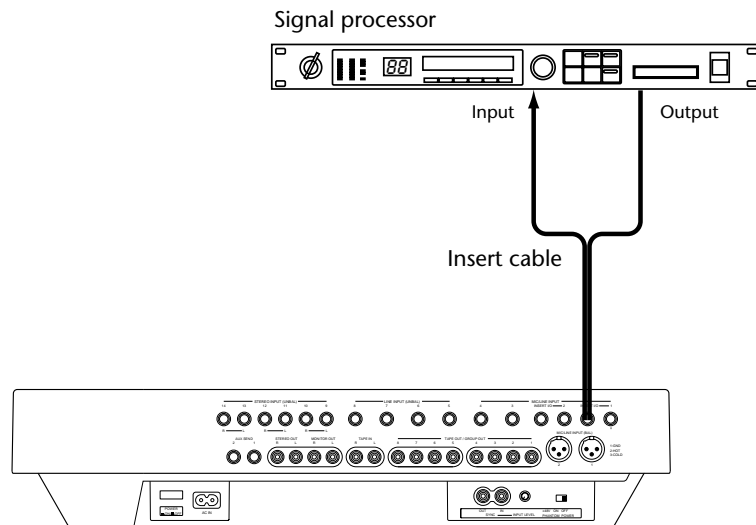

Once connected, operation is the same as normal. The signal source for the external processor is taken after the channel's EQ section. The output signal from the external processor is then returned into the channel just before the fader. The processed signal can then be assigned to the groups, sent to the Stereo bus, or to the auxiliary sends.

7 Tape Speed & Mixing Tips

Using the Tape Speed Function

The Tape Speed function allows you to speed up or slow down the speed of the tape. This has the effect of raising or lowering the pitch of the recorded sounds.

- 1. To adjust the tape speed, first stop playback.**
It's best to stop the MT8XII before switching between the VARI and FIX speed modes.
- 2. Press the [VARI] switch.**
The red VARI indicator lights up.
- 3. Press the [PLAY] button to start playback.**
- 4. Use the speed control to slow down or speed up the tape.**
- 5. When you've finished using the Tape Speed function, press the [FIX] button to select FIX speed mode.**

Even though the rotary tape speed control has a center detent position that equates roughly to normal speed, it is not as precise as using the FIX speed mode.

The following is a discussion of creative applications for the Tape Speed function.

Adjusting the pitch is a common multitrack technique. It's useful when recording instruments that are slightly out of tune. For example, you've recorded the drum and bass parts and now it's time to record the acoustic piano part. However, the piano is a little flat. The easy way around this problem is to record the piano part at a lower pitch with the pianist playing a little slower. When you play back the recording at normal pitch, the piano part is in tune with everything else.

The Pitch function can also be used when recording a vocal phrase with high notes that a vocalist cannot quite reach. For example, drums, bass, guitar, and lead vocals have already been recorded. Now it's time to record the vocal harmonies. The vocalist, however, cannot quite reach some of the high notes. The easy way around this is to record the harmony part at a reduced pitch with the vocalist singing a little slower. When you play back the recording at normal pitch, you have the high notes of the harmony and they're in tune with everything else.

A more advanced pitch technique that can be used to capture a *super-fast* guitar solo, which is difficult to play repeatedly, is to detune your guitar so that it matches the reduced pitch of the MT8XII. Then record the solo at the slower speed and pitch. When you play back the recording at normal pitch, you have a *super-fast* guitar solo that's in tune with everything else.

Mixing Tips

This section provides tips and techniques for achieving the perfect MT8XII mix.

- **Inputs**—for mixdown, the [FLIP] switches are set to the down position and the eight input channels feed the tape signals to the Stereo bus for mixing. Combined with the ST INPUTS, which can be used to connect external effects processors, this provides 14 input sources. If you need to connect more sound sources, the CUE monitors can be used. When the [FLIP] switches are set in the down position, the MIC/LINE input signal is fed to the CUE monitor level and pan controls. Setting the [CUE MIX TO STEREO] switch to ON feeds the CUE monitor signal into the Stereo bus. This provides a total of 20 simultaneous input sources.
- **Balance levels**—you should already have some idea of how you want your mix to sound. This will, obviously, depend on the application and the instruments being mixed. Start with all faders positioned at the 7–8 mark. This is an optimum setting with regard to mixer performance and leaves you with some headroom to increase levels later. If one particular instrument is too quiet, rather than increasing its level it may be better to try reducing the levels of some of the other instruments. If you keep raising faders bit-by-bit, you'll soon end up with some faders set at maximum and no room for further adjustment. Vocal and instrument levels should be balanced to create an agreeable sound mix. Nothing too loud, nothing too quiet. What needs to be heard (i.e., vocals, solo instruments) can be, and backing instruments are where they belong—in the background.
- **Pan the sounds**—pan allows you to position sounds from left to right in the stereo field. This is often used to provide space for individual instruments. Bass instruments and lead vocals are usually panned around center. Rhythm guitar maybe panned to the left and lead guitar or piano, to the right.
- **Balance tonal content**—you can use EQ to filter out any unwanted hiss, hum, or frequency abnormalities in a sound. Instruments with overlapping frequencies often cause peaks at certain points in the audio spectrum when mixed. Using the EQ you can cut back some of these overlapping frequencies. This will improve the separation between instruments and provide a more tonally balanced mix. The overall sound should be tonally balanced so that the low, mid, and high bands of the audio spectrum contain an equal amount of sound energy. Too much bass or treble leads to listening fatigue. With EQ, it is often better to cut than boost.
- **Individual track monitor**—when several instruments are mixed, it can be difficult to make individual judgements about them. By temporarily setting the [FLIP] switches on other input channels to the up position, you can monitor an individual track. If you can hear noise or other unwanted sounds, use this technique to listen to each track in isolation and correct as necessary. Note that if you are using the MIC/LINE inputs to connect sound sources in addition to the tape tracks, you'll hear those sources when you press the [FLIP] switches.
- **Apply effects**—vocal and percussion sounds always benefit from the addition of a little reverb. Reverb adds that professional *sparkle* that you hear on most modern recordings. If you don't yet have an effects processor, a reverb unit is probably the most useful type of effects processor to start with.

8 Quick Locate & Repeat Playback

This chapter explains the MT8XII quick locate and repeat playback functions.

RTZ (Return To Zero)

The Return To Zero function allows you to rewind or fast forward the tape to the 00:00 position with accuracy. Simply press the [RTZ] button to locate the 00:00 position. The tape counter flashes while the 00:00 position is being located.

You can press the [PLAY] button while the MT8XII is locating the 00:00 position so that playback starts as soon as the 00:00 position is located. In this case, the PLAY indicator flashes while the 00:00 position is being located.

Memo 1/Memo 2

Memo 1 and Memo 2 allow you to mark two points on the tape for quick location. This is useful to identify sections of a song or to mark a section that you want to play repeatedly. The Memo 1 and Memo 2 points are also used as the cycle points for the Repeat Playback function.

Entering the Memo Points

1. **Locate to the position at which you want to enter a memo point.**
2. **Press the [MEMO 1] or [MEMO 2] button to enter the Memo 1 or Memo 2 point, respectively.**

The MEMO indicator and number of the corresponding memo point appear on the display

Memo points can be entered while the MT8XII is stopped or during playback, recording, rewinding, or fast forwarding.

The memo points are not stored when the MT8XII is turned off.

Locating the Memo Points

1. **Press the [LOC 1] or [LOC 2] button to locate to the Memo 1 or Memo 2 point, respectively.**

The MT8XII locates the memo point. The number of the memo point being located flashes on the display. When the memo point is located, the MT8XII stops.

If you want the MT8XII to start playback as soon as the memo point is located, press the [PLAY] button while the memo point is being located. The PLAY indicator flashes and playback starts as soon as the memo point is located.

Checking the Memo Points

1. **While holding down the [CHECK] button, press the [MEMO 1] or [MEMO 2] button to check the Memo 1 or Memo 2 point, respectively.**

The position of the memo point appears on the display.

Clearing the Memo Points

1. **Press the [CLEAR] button.**

The memo points are cleared.

If you reset the tape counter, the memo points remain at the same positions on the tape, but at different positions relative to the tape counter.

Repeat Playback

The Repeat Playback function allows you to play the section between the Memo 1 and Memo 2 points repeatedly, as shown below.

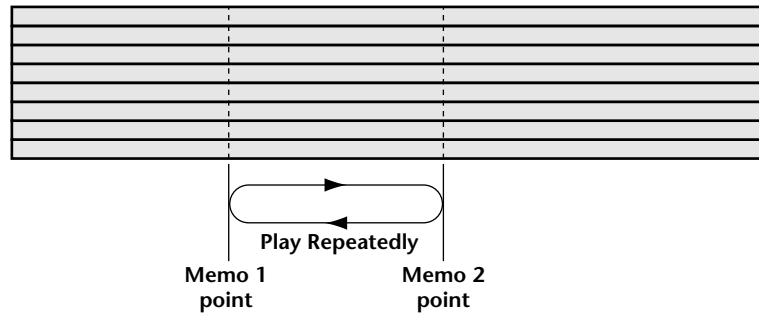

1. Enter the memo points as explained on page 38, *Entering the Memo Points*.
2. Press the [REPEAT] button.

The MT8XII locates the Memo 1 point and starts repeated playback between the two memo points. The REPEAT indicator appears on the display.

Playback is repeated 16 times. Then the MT8XII locates the Memo 1 point and stops. You can stop playback at anytime by pressing the [STOP] button. Pressing the [REPEAT] button during repeat playback cancels the Repeat function, the MT8XII continues normal playback.

If only one memo point has been set, playback repeats between 00:00 and that memo point, as shown below.

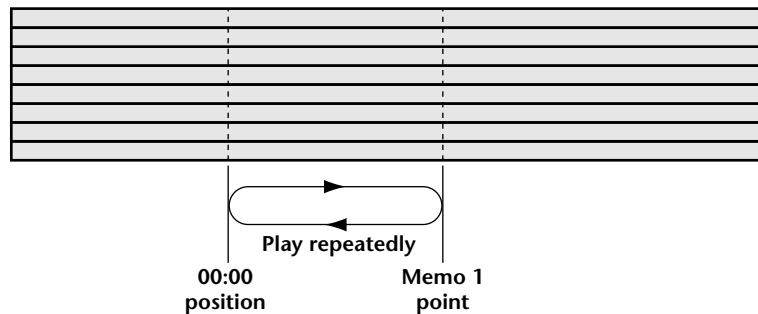

9 The MT8XII & MIDI

MIDI sequencers and MIDI controlled musical instruments have become essential tools for modern recording. It's common these days not to record MIDI instruments to tape until the final mixdown. This has the benefit of freeing up tracks for acoustic sounds and reduces the need for recorders with many tracks. The MT8XII is ideal for recording vocal, guitar, and other acoustic sounds and can easily be integrated into a MIDI system.

Using the MT8XII in a MIDI System

To use the MT8XII in a synchronized MIDI system, you must record a SYNC signal onto Track 8 of the MT8XII before recording anything else. This is called striping the tape, and it only needs to be done once. During playback, the SYNC signal is output from the MT8XII and sent to a MIDI sequencer. The MIDI sequencer reads the SYNC signal and plays back in synchronization with the MT8XII. When the MT8XII is stopped, the MIDI sequencer stops too. In this way, the MT8XII works as the master control device in a synchronized MIDI system. You can still use the transport controls on the MIDI sequencer, but only the MIDI sequencer will respond.

The SYNC signal is recorded and played back on Track 8 of the MT8XII, so you cannot use this track for recording. You can, however, still use Input Channel 8 as an input channel. Although, it's best to keep the [FLIP] switch on channel 8 in the up position and the CUE LEVEL control turned down. Otherwise, you will be able to hear the SYNC signal.

The MT8XII has dedicated input and output connectors for connecting a SYNC signal. Do not connect a SYNC signal to channel 8's line input.

When the SYNC function is on, the dbx noise reduction system is turned off for Track 8. This ensures that the SYNC signal is processed correctly. For this reason, do not record the SYNC signal onto a different track.

SYNC Signal Formats

The MT8XII supports two formats of SYNC signal: SMPTE timecode and FSK. The main difference between these two formats is that SMPTE timecode contains both clock and position information whereas FSK contains only clock information. This means that with SMPTE timecode you can start playback on the MT8XII at any point and the MIDI sequencer will playback in synchronization. With FSK, however, you must always rewind the tape and start playback on the MT8XII at the beginning of the SYNC signal for the MIDI sequencer to synchronize correctly. Some newer FSK converters use what's called "smart FSK". Like SMPTE timecode, this contain both clock and position information, allowing playback start from any position within a song.

In order to stripe the MT8XII tape, you need a device that can generate either SMPTE timecode or FSK. Some MIDI sequencers have this feature built-in. If your's doesn't, you'll need a MIDI/SMPTE or MIDI/FSK converter. These devices convert MIDI clock signals into signals that can be recorded onto tape (i.e., SMPTE timecode and FSK). During playback, the same device is used to convert the SMPTE timecode or FSK signal back into MIDI clock signals for the MIDI sequencer to synchronize to. Stand-alone SMPTE timecode generators can generate SMPTE timecode independently of a MIDI sequencer. The format that you chose will probably depend on your budget. SMPTE is more expensive than FSK, but the benefits are worth it if you intend to do a lot of synchronized recording. A converter box with a built-in MIDI merge function makes setup and operation easier.

Standard audio cables can be used to make SMPTE timecode and FSK connections.

Connecting the MT8XII to a MIDI System

FSK/MIDI System

In this system, an FSK/MIDI converter, such as the Yamaha YMC10, is used to generate the FSK signal that is recorded onto Track 8 of the MT8XII. During playback, the FSK signal is converted to a MIDI Clock signal. When the drum box and synthesizer with onboard sequencer receive the MIDI Clock signal, they both playback in synchronization.

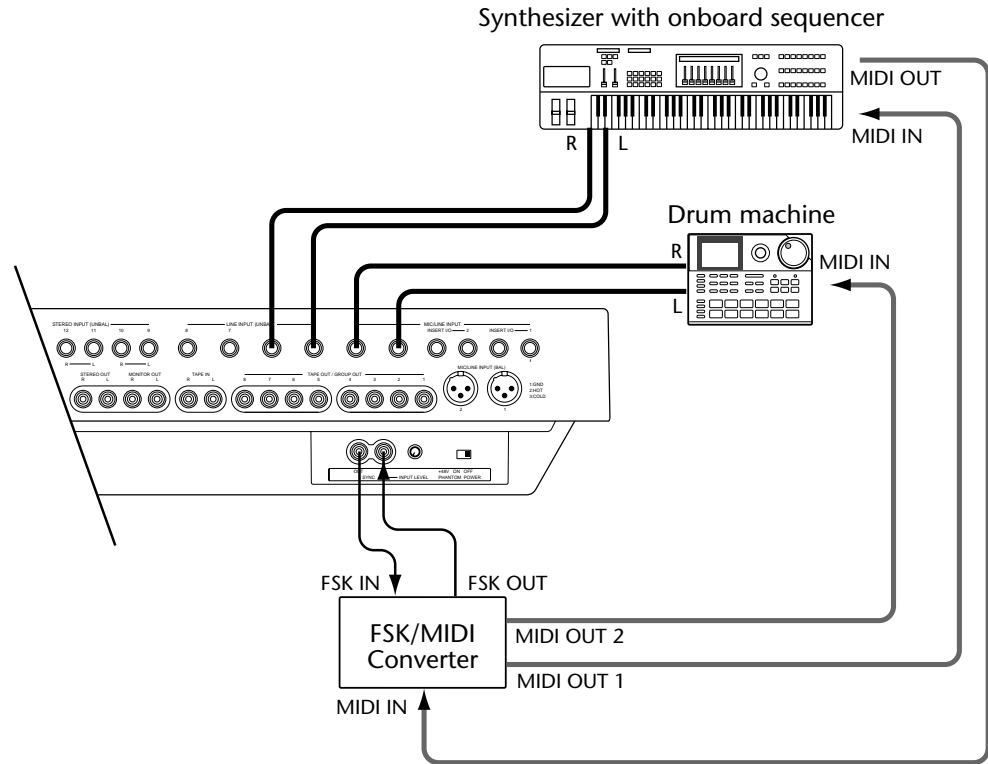

SMPTE/MIDI System

In this system, a SMPTE/MIDI converter is used to generate the SMPTE timecode that is recorded onto Track 8 of the MT8XII. It has a MIDI merge function that merges the MIDI Clock information derived from the SMPTE timecode with the MIDI performance data from the synthesizer. Some MIDI interfaces have two MIDI In jacks. In this case, the merge function is performed by the MIDI interface or MIDI sequencer. The MIDI sequencer is shown with two MIDI OUT jacks. So if you have only one MIDI OUT jack, connect it to the SMPTE/MIDI converter when stripping the tape, then to the synthesizer for subsequent operations.

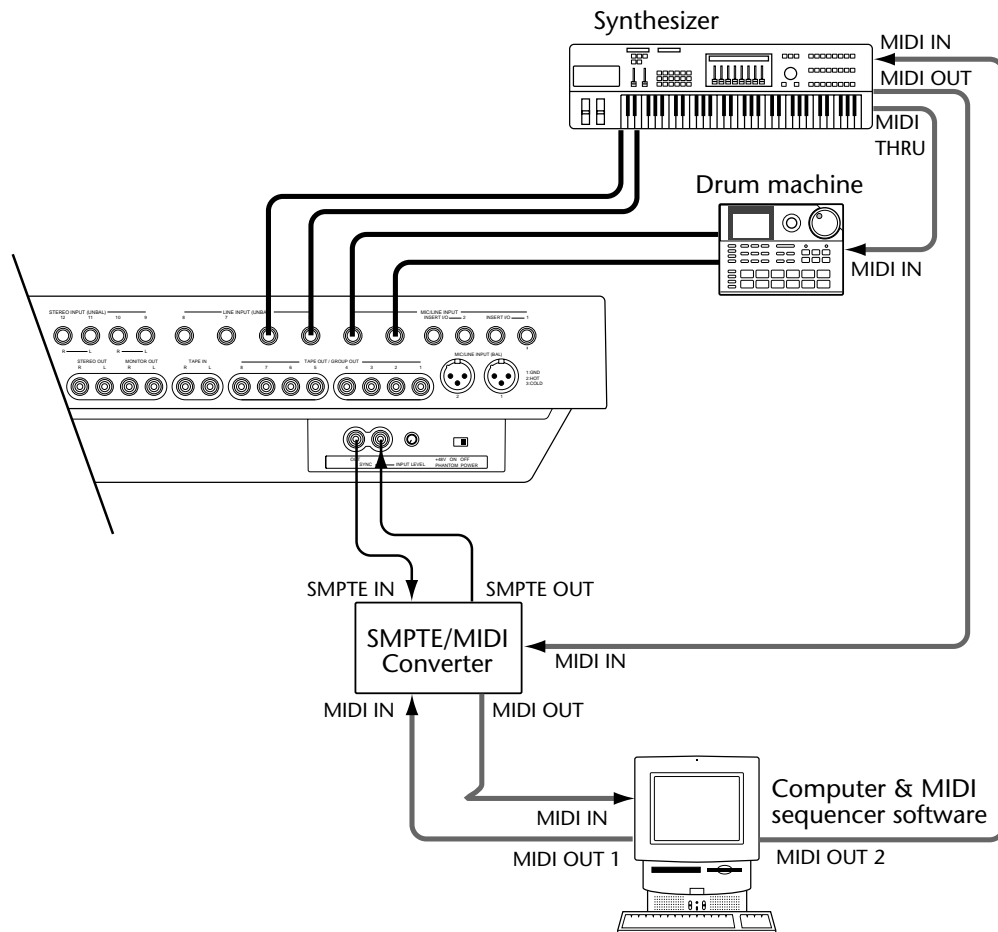

Striping the Tape

1. **Connect the MT8XII to the SMPTE timecode generator or FSK/MIDI converter as shown in the previous section.**
2. **If you are using FSK, press the [SYNC] button once. If you are using SMPTE timecode, press the [SYNC] button twice.**
The SYNC indicator lights up for FSK operation or flashes for SMPTE timecode operation.
It's important that you set the MT8XII to work with the SYNC signal format that you are using, and use the same setting for synchronized playback.
3. **Press the REC SELECT button for Track 8.**
A flashing circle appears around track indicator 8.
4. **Prepare the MIDI sequencer and SMPTE/MIDI or FSK/MIDI converter.**
For SMPTE timecode, typically 30 frames/second is used in the United States and 25 frames/second in Europe.
5. **Set the level of the SYNC signal. You will have to start the MIDI sequencer or SMPTE timecode generator to do this.**
For FSK, set the SYNC LEVEL control on the rear of the MT8XII midway.
6. **Press the [REC/PAUSE] button.**
The REC/PAUSE indicator lights up and the MT8XII waits in Record Pause mode.
7. **Press the [PLAY] button to start recording.**
The PLAY indicator lights up and recording starts.
8. **After about 5 seconds, start the MIDI sequencer.**
The SYNC signal is recorded onto Track 8.

Stripe the tape for the length of the song to be recorded. It's a good idea to record the SYNC signal beyond the end of the song. Then you can easily extend the song. You can't make the SYNC signal longer once it's been recorded.

Synchronized Operation

1. **Press the [RTZ] button to rewind the tape back to 00:00.**
2. **Press the [REC SELECT] button for Track 8 to unselect it.**
3. **Set the SMPTE/MIDI or FSK/MIDI converter for conversion in the opposite direction (i.e., SMPTE or FSK to MIDI).**
4. **Set the MIDI sequencer for external synchronization.**
Refer to your MIDI sequencer's user manual for more information.
5. **Press [PLAY] on the MT8XII.**
The MIDI sequencer should synchronize and play along with the MT8XII.

You can now record sounds to the MT8XII tracks and record MIDI performance data to the MIDI sequencer, which is synchronized to the MT8XII. The overdub, ping-pong, and mixdown techniques work the same for synchronized operation. The MT8XII outputs the SYNC signal during playback, rehearsal, and recording. So the MT8XII and MIDI sequencer work together seamlessly.

10 MT8XII Applications

This chapter shows how the MT8XII can be used for various applications.

One-Take Recording

The One-Take recording technique is ideal for live recording or recording bands that like to record with all members playing together. In the following system example, vocals, guitar, and drums are recorded using microphones, the bass is connected via a DI connection, and the synthesizer is connected directly. A stereo pair of headphones is used for monitoring.

The MT8XII provides four-track simultaneous recording. So there are two options for one-take recording: 1) mix and record all inputs to four tracks. 2) Record the four backing tracks first, then record the remaining tracks while monitoring the backing tracks.

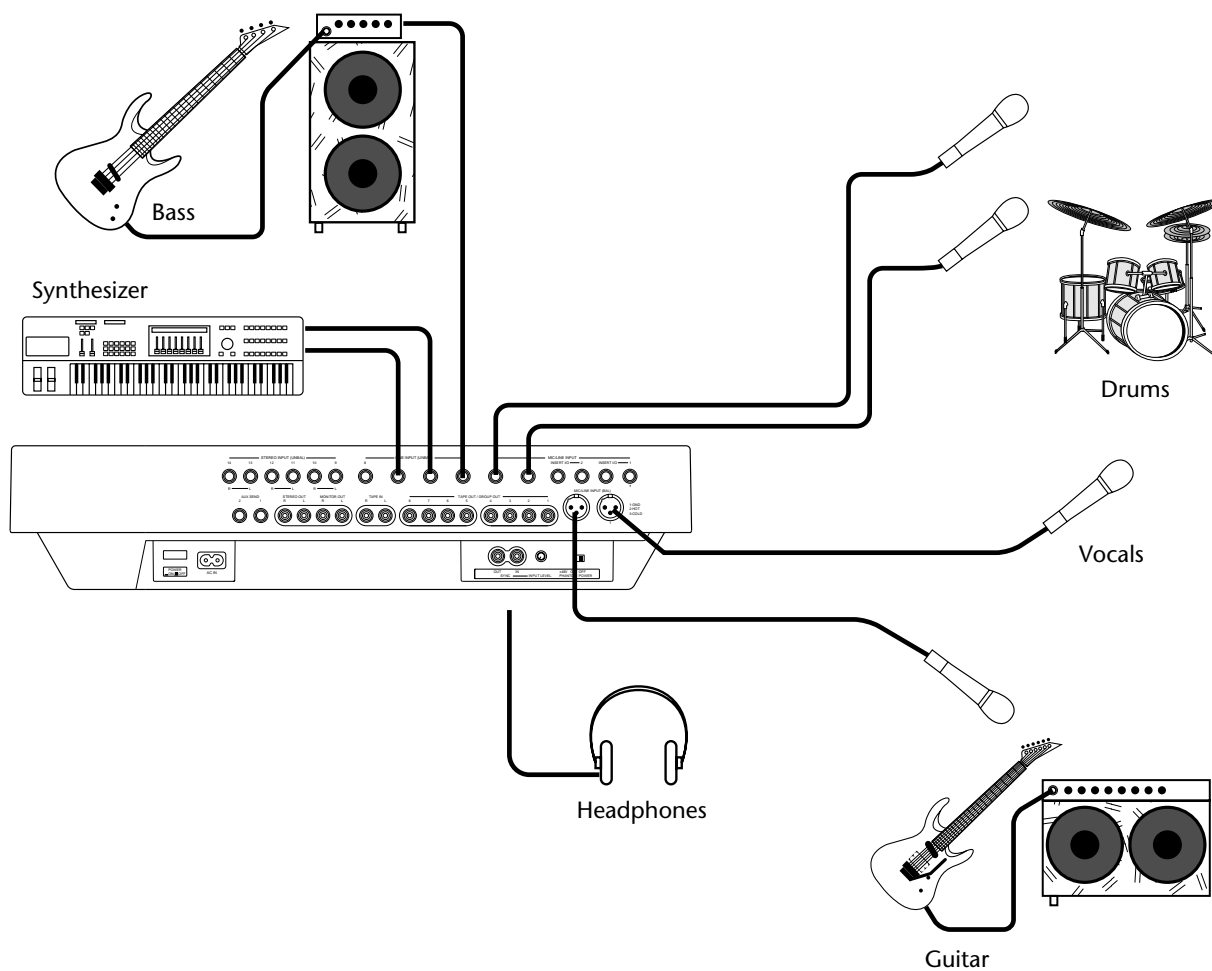

MIDI Home Studio

In the following MIDI home studio system example, all instruments are recorded to the MT8XII. Recording the MIDI instruments could be left until the final mixdown, since the MIDI sequencer provides repeatable playback and is synchronized to the MT8XII using SMPTE time-code. Having the entire project on an MT8XII tape, however, does simplify media management.

A monitor amp and speakers are used for monitoring. Two external effects processor are connected to the AUX SENDS and ST INPUTs for effects processing. A compressor/limiter is patched into Input Channel 1 to provide a more consistent level on vocals. A graphic equalizer is patched in between the STEREO OUTs and the master recorder. During mixdown, the output of the master recorder can be monitored by setting the TAPE IN switch to TO MONITOR.

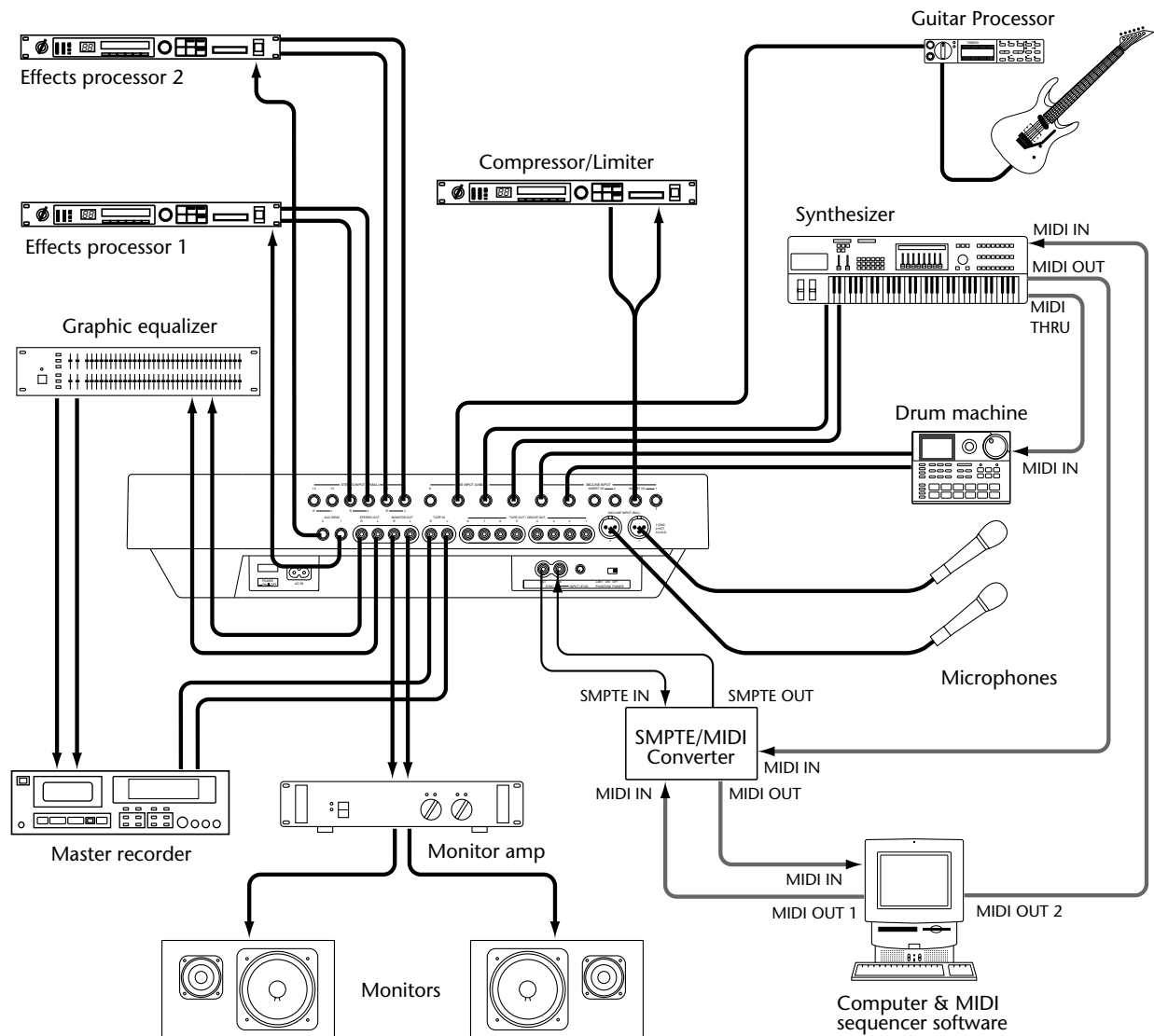

Multi-Source Mixing

This example shows how multiple sound sources can be mixed on the MT8XII. To start, an SMPTE SYNC signal is recorded on Track 8. This is used to synchronize the MIDI sequencer that in turn controls the MIDI instruments, which are permanently connected to the MT8XII and are recorded to tape only at mixdown. The acoustic instruments and vocal microphones are connected to MIC/LINE inputs 1 and 2 as and when they are needed. The MIDI instrument sounds are monitored while the acoustic sounds are recorded to the MT8XII tracks using the overdub technique. When all the acoustic sounds have been recorded, the [FLIP] buttons are used to determine whether the tape signals or MIC/LINE signals (MIDI instruments) are fed to the input channels or CUE controls. Sounds that require EQ and effects should be fed to the input channels. Finally, the [CUE MIX TO STEREO] switch is set to ON and the tape sounds and MIDI instrument sounds are all mixed down into a stereo mix, which is then recorded to the master recorder. The output of the master recorder is shown connected to the TAPE IN. You could, however, connect another sound source to the TAPE IN and add that to the mix. Also, once the acoustic sounds have been recorded, MIC/LINE inputs 1 and 2 could be used to connect other sound sources, other MIDI instruments, for example. On input channel 8, keep the [FLIP] switch in the up position and the CUE LEVEL control turned down. Otherwise, you'll hear the SYNC signal playing on Track 8.

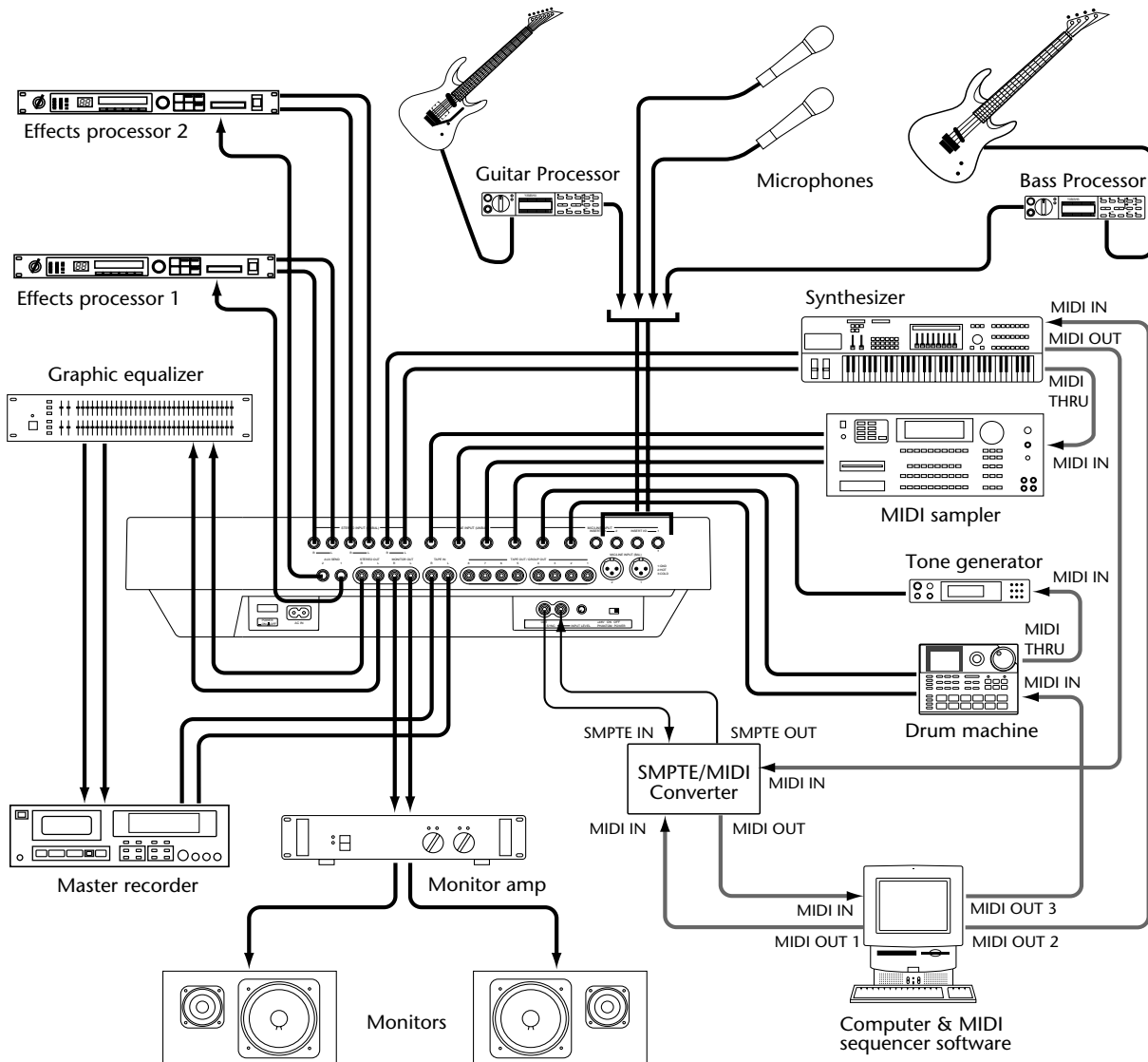

Using the TAPE OUT/GROUP OUTs

The TAPE OUT/GROUP OUT connectors can be used to send the tape playback signals or group signals to other equipment. The MT8XII has four groups buses. So up to four group signals can be output simultaneously. During playback, the eight tape signals are output.

In this example, the MT8XII tape signals are fed to a sub mixer for mixdown.

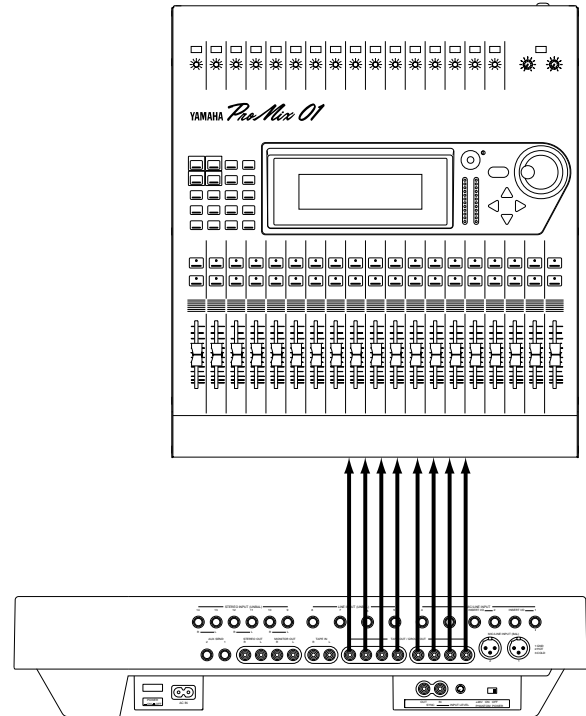

In this example, the MT8XII tape signals are fed to an external multitrack recorder. This multitrack recorder could be used instead of the MT8XII recorder section. This method can also be used to transfer the eight tracks of an MT8XII tape to another multitrack recorder.

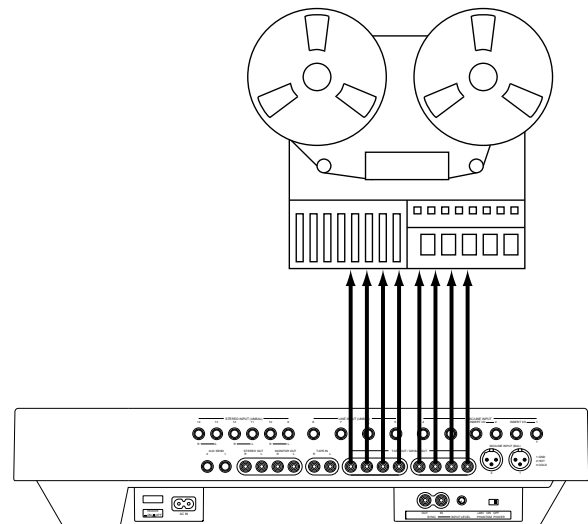

Troubleshooting

If you're having difficulty operating MT8XII or it doesn't seem to work as expected, look up the symptoms in the following table and follow the advice provided.

Symptom	Advice
MT8XII cannot be turned on!	Make sure the power cord is connected to a suitable AC wall outlet and plugged into the AC IN connector at the rear of the MT8XII.
	Make sure that the MT8XII POWER switch is set to the ON position.
	If you still cannot turn on your MT8XII, contact your Yamaha dealer.
Cannot listen to a connected music source!	Make sure that the input selector switch is set to MIC/LINE. Raise the input channel fader. Assign the input channel to a track using the GROUP ASSIGN switches. Press the corresponding MONITOR SELECT GROUP switch. Turn up the MONITOR LEVEL control.
Cannot record!	Make sure the tape's write protect tabs are intact.
	Be sure to press a [REC SELECT] button to select a track for recording?
	Make sure that you have actually assigned the signal that you want to record to the track. Use the CUE monitor controls to see if the signal is actually being sent to the track.
The level meters do not indicate signal levels!	Normally, the level meters indicate tape signal levels. To see the level of a group signal you must press the corresponding [REC SELECT] button.
Recordings are noisy!	Use the dbx noise reduction.
	Make sure that the recording level is set correctly. Too low a signal level will cause the tape hiss to be more noticeable.
Recordings are distorted!	Make sure that the recording level is set correctly. Too high a signal level will cause distortion.
Recordings sound dull!	Clean the record-play head and other parts of the tape transport. Demagnetize the record-play head.
Abnormal tape hiss!	
Wow and flutter	
Fluctuating output level!	
Recordings play back at the wrong pitch!	You may have adjusted the pitch prior to recording a track. Reset the pitch as required.
Cannot send a channel signal to the AUX SEND!	As well as turn up the AUX control you must also raise the channel fader. This is because the AUX SEND signal is sourced post-fader (i.e., after the fader).
MIDI sequencer does not synchronize to the MT8XII!	Have you recorded a SYNC signal on Track 8?
	Make sure that the FSK/MIDI or SMPTE/MIDI converter is set to convert the recorded SYNC signal into a MIDI Clock signal.
	Make sure your MIDI sequencer is set to synchronize to an external source. Refer to the MIDI sequencer's user manual.

Appendix

Maintaining the MT8XII

The MT8XII requires regular maintenance to remain in top working condition. You should perform the following two maintenance procedures before each new recording session or when you notice any of the following symptoms:

- Increased tape hiss
- Dull sounding recordings (i.e., high-frequency loss)
- Wow and flutter
- Fluctuating sound or signal output

Cleaning the Record–Play Head and Other Parts

As the tape passes over the record–play head, a tiny amount of oxide residue is left on the head. During normal use, this oxide can build up to the point where audio performance is affected. Therefore, you should clean the record–play head, capstan, pinch roller, and erase head at regular intervals using a commercially available head-cleaning kit. These kits usually contain specially-made cotton swabs and an isopropyl alcohol-based cleaning solution, and are available at audio and electronics shops. Follow the directions on the kit, carefully wiping the record–play head, capstan, and erase head with a swab soaked in cleaning solution. It's best to clean the pinch roller with a non-alcohol based rubber cleaning solution, which is often included in the cleaning kits. Alcohol tends to dry out and corrode the rubber part of the roller. It's recommended that you clean the record–play head, capstan, pinch roller, and erase head before each new recording session or after every 10 hours of use, whichever comes first.

For easy access to the tape heads and other parts, MT8XII features a Maintenance mode. In this mode, the tape heads are raised just like when a cassette is inserted. To enter Maintenance mode:

1. **While holding down the [PLAY] and REC SELECT [1] buttons, turn on the MT8XII.**
REMAIN flashes on the display.
2. **Open the cassette compartment.**
3. **Press the [PLAY] button.**
The heads rise up from under the head cover, providing easy access for cleaning.
4. **Press the [STOP] button to lower the heads.**
5. **When you've finished, turn off the MT8XII, wait a few seconds, and then turn on again.**

Note: Be sure to cancel Maintenance mode by turning off the MT8XII before continuing with normal operation.

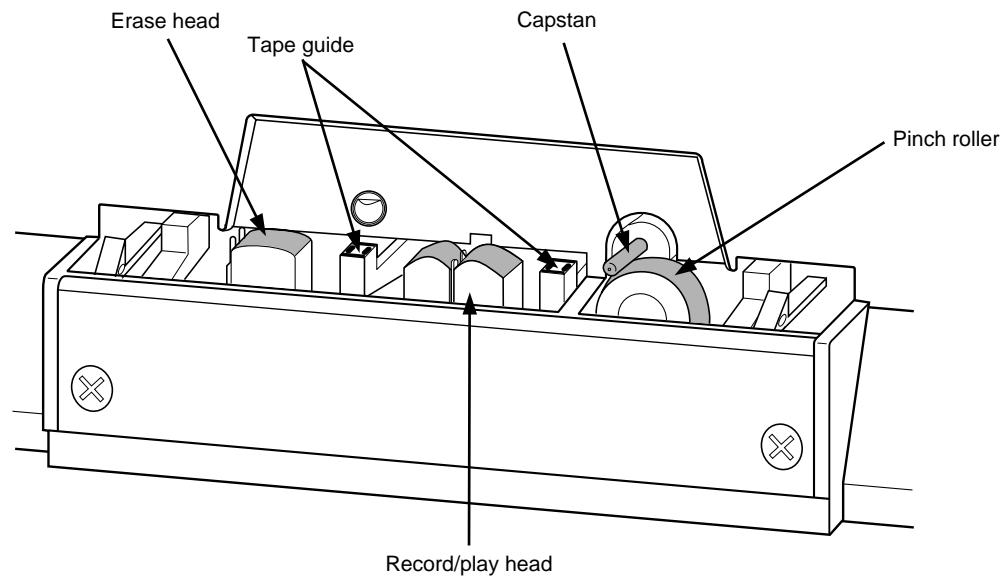

Demagnetizing the Record–Play Head

As the tape passes over the record–play head, it imparts a tiny amount of magnetism to the head. During normal use, this magnetism can build up to the point where audio performance is affected. Therefore, you should demagnetize the record–play head at regular intervals using a commercially available tape head demagnetizer. These are available at most audio and electronics shops. A hand-held demagnetizer is preferable to the cassette-type demagnetizers.

It's recommended that you demagnetize the record–play head before each new recording session or after 25 hours of use, whichever comes first.

Caution: Turn off the MT8XII before demagnetizing the record–play head.

The demagnetizer should be turned on away from the MT8XII, passed slowly across the face of the record–play head, and then drawn away slowly from the MT8XII and turned off.

Caution: Read the directions on the demagnetizer carefully. Misuse can damage the record–play head. Also, do not place the demagnetizer close to magnetic storage media, such as audio tapes and floppy disks. The demagnetizer emits a strong magnetic field and can erase all information stored on such media.

Specifications

Mixer

Frequency Response	LINE IN (GAIN max.)–STEREO OUT	20 Hz–20 kHz +1, –4 dB
	LINE IN (GAIN min.)–STEREO OUT	
	LINE IN (GAIN min.)–PHONES	
Noise Level (12.7 kHz: –6 dB/oct. L.P.F.)	Equivalent Input Noise	–115 dB (Rs=150 Ω)
	STEREO OUT	–80 dB/CH (STEREO fader at 7–8 mark)
S/N Ratio (at rated input & output levels)	LINE IN (GAIN max.)–STEREO OUT	68 dB, IHF-A
	LINE IN (GAIN min.)–STEREO OUT	70 dB, IHF-A
Distortion (1 kHz signal at rated input & output levels)	LINE IN (GAIN max.)–STEREO OUT	0.3% (30 kHz L.P.F.)
	LINE IN (GAIN min.)–STEREO OUT	0.05% (30 kHz L.P.F.)
EQ	LOW	±12 dB @ 80 Hz, shelving
	MID	±12 dB @ 250 Hz–5 kHz, sweepable
	HIGH	±12 dB @ 12 kHz, shelving

Tape Transport

Tape Type	C46–C90, CrO ₂ (Bias: HIGH, EQ: 70 μs)	
Track Configuration	8-track	
Tape Heads	Record–play	8-track Hard Permalloy
	Erase	8-track ferrite
Motors	Capstan	DC servo motor x1
	Reel	DC motor x1
	Mechanism	DC motor x1
Tape Speed	9.5 cm/sec	
Pitch Control	Approximately ±12%	
Wow & Flutter	Less than 0.08% WRMS	
Rewind Time	Normal Rewind	Approximately 95 seconds for a C60 tape
	High-Speed Rewind	Approximately 75 seconds for a C60 tape

Recorder

Overall Frequency Response	50 Hz–14 kHz +3, –5 dB (dbx NR off)
Overall S/N Ratio	80 dB/IHA-F (at 3% distortion level, dbx NR on)
Overall Distortion	2% (400 Hz, –10 dB)
Overall Channel Separation (adjacent channels)	60 dB (1 kHz, –10 dB, dbx NR on)
Erasement Rate	55 dB (1 kHz, 0 dB)
Noise Reduction	dbx NR (SYNC position: TR8 = off)

General

Power Requirements	Local AC Current
Power Consumption	46 W
Dimensions (W x H x D)	530 x 132.6 x 416.4 mm (20.8" x 5.2" x 16.4")
Weight	7.6 kg (16.7 lbs)
Supplied Accessories	AC power cord, <i>Owner's Manual</i> , cleaning kit
Optional Accessories	FC5 Footswitch

Input Connections

Connection	Input Impedance	Rated Input Level	Minimum Input level	Connectors
MIC/LINE 1, 2	balanced 5 k Ω	-16 dB to -60 dB (CH fader at 7-8)	-66 dB (GAIN & fader max.)	XLR-3-31 Type (balanced) Phone jacks (balanced)
	unbalanced 10 k Ω	-10 dB to -54 dB (CH fader at 7-8)	-60 dB (GAIN & fader max.)	
INSERT IN 1, 2	10 k Ω	-10 dB	-16 dB (CH fader max.)	Ring of TRS phone jacks
MIC/LINE 3, 4	10 k Ω	-10 dB to -50 dB (CH fader at 7-8)	-56 dB (GAIN & fader max.)	Phone jacks (unbalanced)
LINE 5-8	10 k Ω	-10 dB (CH fader at 7-8)	-16 dB (fader max.)	Phone jacks (unbalanced)
STEREO INPUT 9-14	20 k Ω	-10 dB (LEVEL nominal)	-16 dB (LEVEL max.)	Phone jacks (unbalanced)
TAPE IN L, R	10 k Ω	-10 dB (LEVEL nominal)	-16 dB (LEVEL max.)	Phono jacks
SYNC IN	10 k Ω	-10 dB (LEVEL center)	-16 dB (LEVEL max.)	Phono jack

Output Connections

Connection	Output Impedance	Min. Load Impedance	Output Level	Connectors
INSERT OUT 1, 2	100 Ω	10 k Ω	-10 dB (10 k Ω load)	Tip of TRS phone jacks
AUX SEND 1, 2	1 k Ω	10 k Ω	-10 dB (10 k Ω load)	Phone jacks
STEREO OUT L, R	1 k Ω	10 k Ω	-10 dB (10 k Ω load)	Phono jacks
MONITOR OUT L, R	1 k Ω	10 k Ω	-10 dB (10 k Ω load)	Phono jacks
PHONES	8-40 Ω	—	100 mW (40 Ω load)	Stereo phone jack
TAPE OUT/ GROUP OUT 1-8	100 Ω	10 k Ω	-10 dB (10 k Ω load)	Phono jacks
SYNC OUT	100 Ω	10 k Ω	-10 dB (10 k Ω load)	Phono jack

0 dB is referenced to 0.775 V r.m.s.

Specifications are subject to change without notice.

Block Diagram

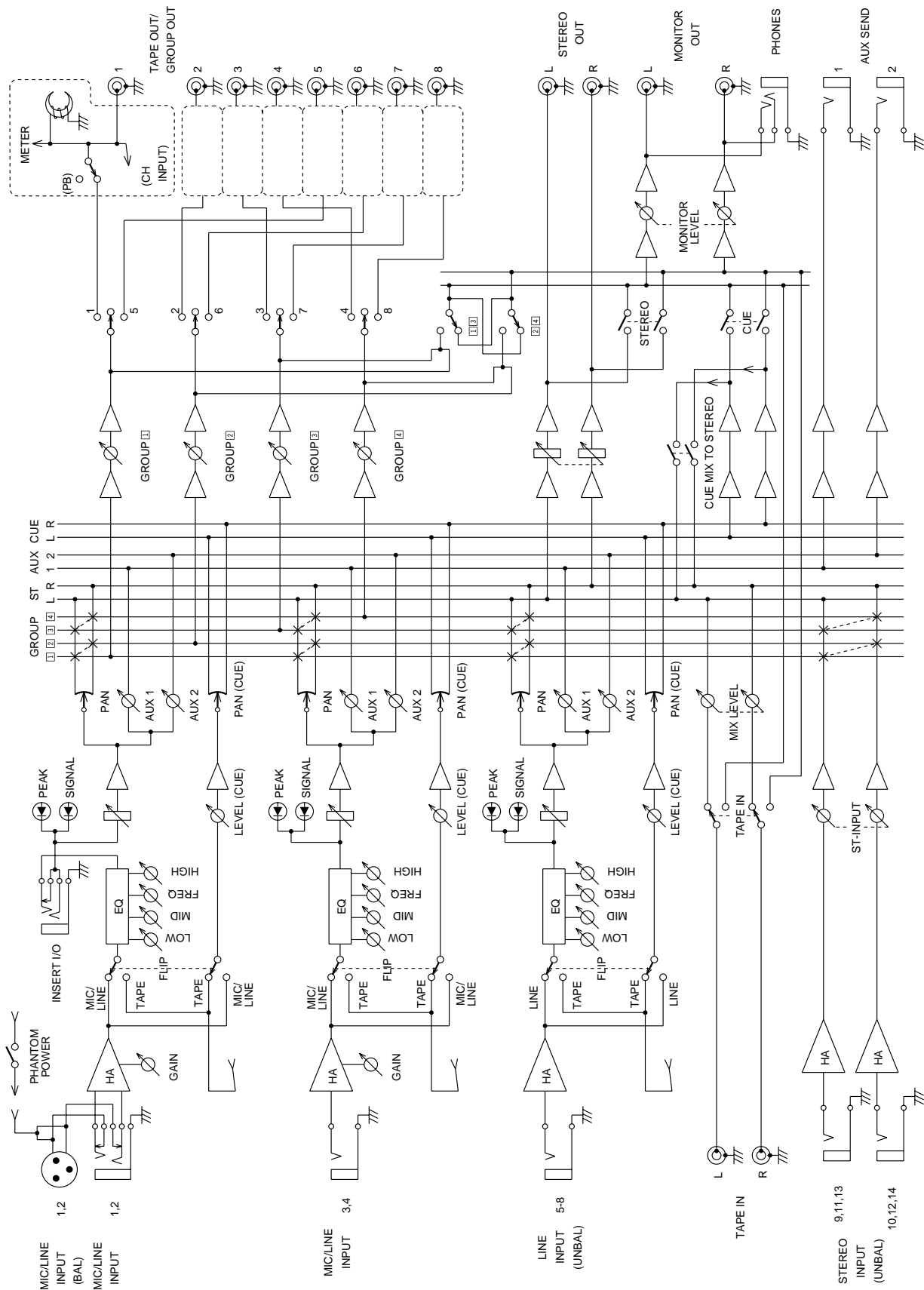

Dimensions

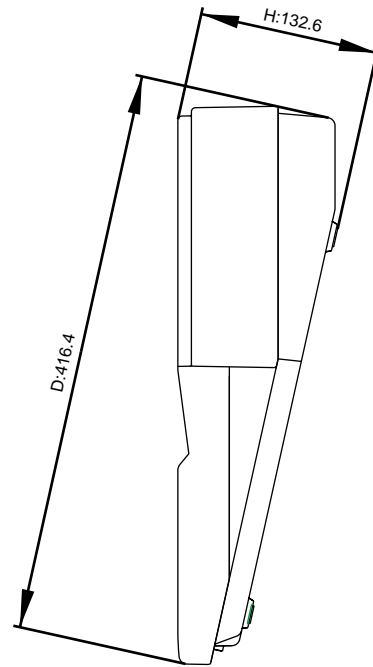
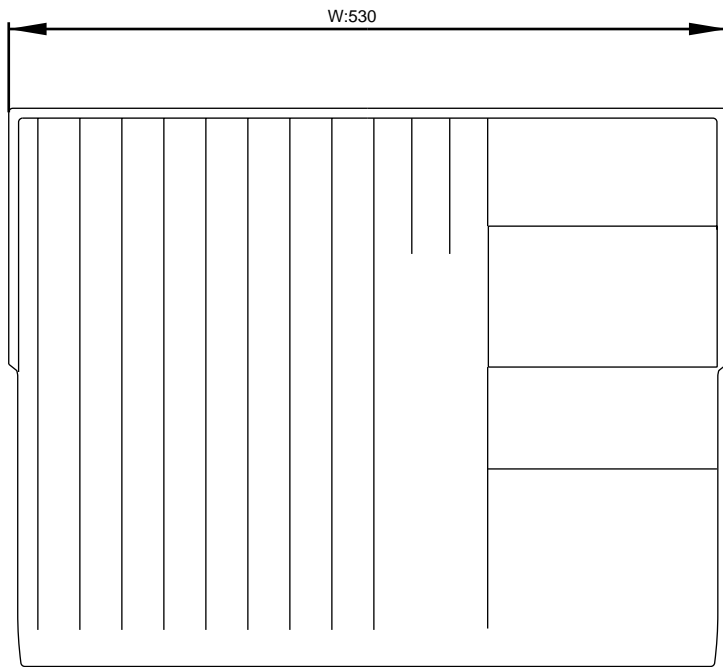

Glossary

Bouncing—See Ping-Pong.

Bus—A common conductor used to collect and distribute audio signals. MT8XII has four Group buses that feed the tracks, a Stereo bus consisting of left and right channels, two AUX buses for the AUX SENDs, and a stereo CUE bus for the cue monitor.

Capstan—The cylindrical shaft of the capstan motor, which is used in conjunction with the rubber pinch roller to drive the tape at a constant speed.

Clipping—The unwanted distortion effect of overloading an audio circuit with a signal that is too large. Care must be taken when setting the MT8XII GAIN controls so as not to overload the recording circuits. See *Recording the First Track* on page 15 for more information.

CUE Monitor—The cue monitor allows you to monitor individual tracks as they are being recorded or played back. In Record Pause mode and during recording, the CUE monitor source is the signal being recorded (i.e., the input signal). For playback, the CUE monitor source is the tape signal. This is useful with the punch in/out functions, because you can monitor the recorded signal up to the specified IN point, and then the new signal that's being recorded up to the OUT point.

DAT—An acronym for Digital Audio Tape. DAT recorders are especially popular in recording studios for recording the final stereo mix.

dbx Noise Reduction—A noise reduction system for improving the noise performance of analog tape recorders. During recording, pre-emphasis and 2:1 compression are applied to signals. During playback, 1:2 expansion and de-emphasis are applied to restore signals to their original form. Because the tape hiss was not present in the original signal, it is greatly reduced by this process.

Demagnetizer—A hand-held device used to demagnetize (also called degauss) tape heads and other metal parts that come into contact with a moving magnetic tape.

DI (Direct Inject)—A technique for connecting an electric guitar or bass guitar directly to a mixer. The high output impedance of the guitar is matched with the low impedance of the mixer input using a DI Box. Some instrument amplifier's feature a DI connection.

EQ—An acronym for an audio equalizer. MT8XII input channels feature three-band EQ with a sweepable MID band.

Footswitch—A foot operated switch. On the MT8XII, an optional footswitch can be used to perform manual punch in/out.

FSK (Frequency Shift Keying)—A type of synchronization signal that uses frequency shift techniques. An FSK synchronization signal can be recorded on Track 8 of the MT8XII. During playback, the FSK signal is converted to MIDI Clock signals to control a MIDI sequencer. An optional FSK/MIDI converter, such as the Yamaha YMC10, is required for this.

Group—A group allows several input signals to be mixed together and recorded to a single track. For MT8XII recording, input signals are assigned to a group. From there, they are sent to the tracks for recording. The overall level of group is controlled by the GROUP MASTER level control.

Line-Level Signal—A signal in the range from -20 dB to +20 dB. These are essentially high-level signals. Most audio equipment outputs signals at line level. All MT8XII inputs and outputs support line-level signals. *Contrast with* Low-Level Signal.

Low-Level Signal—A signal in the range from -100 dB to -20 dB. Microphone and electric guitar signals are in this range. MT8XII MIC/LINE inputs support low-level signals. *Contrast with* Line-Level Signal.

MIDI—An acronym for Musical Instrument Digital Interface. An internationally agreed standard that allows electronic musical instruments and audio equipment to communicate.

Mixdown—The process of mixing the individual track signals into a well-balanced stereo mix. Mixdown is the final stage of the multitrack recording process.

Multitracker—An all-in-one recording and mixing device, such as the MT8XII, usually with four or eight tracks.

Nominal Level—*See* Operating Level.

One-Take Recording—A recording technique in which all sounds are recorded in one go (i.e., no overdubs). This is used for live recording.

Operating Level—This is the signal level at which a piece of audio equipment is designed to operate. The two most common operating levels are -10 dBV (316 mV), which is used for semi-professional equipment, and $+4$ dBu (1.23 V), which is used for professional equipment.

Overdub Recording—The process of recording additional sounds while listening to previously recorded sounds. It allows songs to be built up track-by-track.

Panning—A technique used to position sounds in a stereo mix.

Phone Jack—A 1/4-inch socket commonly used on audio equipment.

Phono Jack—Also known as an RCA jack, this type of connector is often used on semiprofessional audio and video equipment.

Pinch Roller—The small rubber wheel that pinches the tape between itself and the capstan to drive the tape.

Ping-Pong—A recording technique used to transfer (i.e., mix and rerecord) one or more tracks to other tracks to free up those tracks for further recording.

Pre-Roll Point—This is the point before the actual punch in point at which the Auto Punch In/Out sequence starts. When the Auto Punch In/Out sequence is complete, MT8XII rewinds automatically to the pre-roll point.

Post Fader—A point in the signal path after a fader. The signals for the MT8XII AUX controls are sourced post-fader. So as well as turning up the AUX control, you must also raise the fader. This has the advantage that the level of the processed signal from the external effects processor is controlled in unison with the unprocessed signal that is controlled by the fader.

Post-Roll Point—This is the point five seconds after the actual punch out point at which the Auto Punch In/Out sequence ends, and MT8XII rewinds automatically to the pre-roll point.

Punch In/Out—A recording technique that allows you to rerecord specific sections of an existing track. MT8XII provides both manual and automatic punch in/out operations.

RTZ—An abbreviation for Return To Zero. Pressing the [RTZ] button on the MT8XII rewinds automatically to the 00:00 tape position.

Signal—Sounds travel through audio equipment as electrical signals.

Signal to Noise Ratio (S/N)—In an audio system, the difference between the nominal signal level and the residual noise floor, usually expressed as a ratio in decibels. It's used as a measure of an audio system's noise performance.

SMPTE Timecode—Pronounced “simply”, SMPTE timecode is the timecode format used for television tape recorders by the SMPTE (Society of Motion Pictures and Television Engineers) in the United States and the EBU (European Broadcast Union) in Europe. Unlike FSK that consists of simple clock information, SMPTE timecode contains clock and position information. So playback can be started at any position on the tape. SMPTE timecode can be recorded on Track 8 of the MT8XII. During playback, the SMPTE timecode is converted to MIDI Clock signals to control a MIDI sequencer. An optional SMPTE/MIDI converter is required for this.

Stripping the Tape—The process of recording a SYNC signal onto one track of a tape for synchronized playback with a MIDI sequencer. You can record a FSK or SMPTE timecode SYNC signal onto MT8XII Track 8. This should be done before recording anything else.

Tracking—The process of recording sounds to tracks on an audio recorder. Also known as *laying down tracks* and just plain simple *recording*. Tracking is the first stage of the multitrack recording process.

Unity Gain—A gain of one. That is, the signal is output from a circuit at the same level at which it entered. Once passed the MIC/LINE amplifier, a unity gain system minimizes signal noise and distortion. The unity gain position for MT8XII faders is at the 7–8 mark.

Mixer Setup

Source:	Source:	Source:	Source:	Source:	Source:	Source:	Source:	Source:	Source:	Source:
1	2	3	4	5	6	7	8	9-10	11-12	13-14
<p>GAIN, LINE/MIC, HIGH, FREQ, MID, LOW, AUX 1, AUX 2, CUE, PAN, MIC/LINE, TAPE, FLIP, PAN, ODD GROUP ASSIGN, EVEN GROUP ASSIGN, PEAK, SIGNAL</p>								<p>ST-INPUT, MIX LEVEL, TO MONITOR, TO STEREO, GROUP, STEREO, CUE MONITOR SELECT, MIN, MAX, MONITOR LEVEL</p>		
<p>10, 9, 8, 7, 6, 5, 4, 3, 2, 1, 0</p>								<p>10, 9, 8, 7, 6, 5, 4, 3, 2, 1, 0</p>		
1	2	3	4	5	6	7	8	STEREO		

MT8XII Tracking Sheet

Track List							
1	2	3	4	5	6	7	8

Session Info
Title:
Date:
Step:
Process:
Notes: