

# SPEAKER SYSTEM

## Installation Series

**IF3115/64(W), IF3115/95(W),  
IH2000/64(W), IH2000/95(W),  
IL1115(W)**

## OWNER'S MANUAL

Thank you for choosing this Yamaha speaker system. In order to take maximum advantage of the speaker's features and ensure optimum performance and longevity, please read this manual carefully before using the speaker system. Keep the manual in safe place for future reference.

## BEDIENUNGSANLEITUNG

Vielen Dank für die Auswahl dieses Lautsprechersystems von Yamaha. Damit Sie die Eigenschaften dieses Lautsprechers optimal nutzen können, und um maximale Leistung und Lebensdauer sicherzustellen, lesen Sie bitte vor der Inbetriebnahme diese Anleitung sorgfältig durch. Bitte bewahren Sie diese Anleitung zum späteren Nachschlagen an einem sicheren Ort auf.

## MODE D'EMPLOI

Nous vous remercions d'avoir acheté ces enceintes Yamaha. Pour obtenir les performances optimales de vos enceintes et garantir une longévité maximale, lisez attentivement ce mode d'emploi avant d'utiliser les enceintes. Conservez-le en lieu sûr pour pouvoir vous y référer ultérieurement.

## MANUAL DE INSTRUCCIONES

Gracias por escoger este sistema de altavoces Yamaha. A fin de aprovechar al máximo las características de los altavoces y obtener un rendimiento y durabilidad óptimos, lea atentamente este manual antes de utilizar el sistema. Guarde este manual en un lugar seguro para futuras consultas.

## 取扱説明書

このたびは、ヤマハ製品をお買い求めいただきまして、まことにありがとうございます。  
スピーカーの優れた性能を十分に生かして、末永くご愛用いただくために、この取扱説明書をご使用の  
前に必ずお読みください。

# PRECAUTIONS

## PLEASE READ CAREFULLY BEFORE PROCEEDING

\* Please keep this manual in a safe place for future reference.



### CAUTION

Always follow the basic precautions listed below to avoid the possibility of physical injury to you or others, or damage to the device or other property. These precautions include, but are not limited to, the following:

#### Location

- Always consult qualified Yamaha service personnel if the device installation requires construction work, and make sure to observe the following precautions.
  - Choose mounting hardware and an installation location that can support the weight of the device.
  - Avoid locations that are exposed to constant vibration.
  - Make sure to use the specified hardware.
  - Inspect the device periodically.
- When transporting or moving the device, always use two or more people. Attempting to lift the device by yourself may damage your back, result in other injury, or cause damage to the device itself.
- Before moving the device, remove all connected cables.
- Do not expose the device to excessive dust or vibrations, or extreme cold or heat (such as in direct sunlight, near a heater, or in a car during the day) to prevent the possibility of panel disfiguration or damage to the internal components.
- Do not place the device in an unstable position where it might accidentally fall over.

#### Connections

- Before connecting the device to other devices, turn off the power for all devices. Before turning the power on or off for all devices, set all volume levels to minimum.
- Use only speaker cables for connecting speakers to the speaker jacks. Use of other types of cables may result in fire.
- Be sure to observe the amplifier's rated load impedance (see page 14), particularly when connecting speakers in parallel. Connecting an impedance load outside the amplifier's rated range can damage the amplifier.

#### Handling caution

- When choosing a power amplifier to use with your speakers, make sure that its power output matches the speakers' power capacity (refer to the Specifications on page 14). Even if the amplifier's power output is lower than the speakers' power capacity, the speakers may be damaged when clipping of a high input signal occurs. The following may cause damage to speakers:
  - Feedback caused when using a microphone.
  - Continuous high sound pressure level produced by electronic instruments.
  - Continuous high-power output of distorted signals.
  - Popping noises caused by turning on equipment, or by connecting or disconnecting system components while the amplifier is turned on.
- When turning on the AC power in your audio system, always turn on the power amplifier LAST, to avoid speaker damage. When turning the power off, the power amplifier should be turned off FIRST for the same reason.
- Do not operate this device at high volume levels or at a level that is uncomfortable, since it is capable of producing sound levels that could cause permanent hearing loss. If you experience any discomfort or ringing in the ears, or suspect an hearing loss, you should consult an audiologist.

Yamaha cannot be held responsible for damage caused by improper use or modifications to the device.

\* Illustrations herein are for explanatory purposes only, and may not match actual appearance during operation.

\* Company names and product names herein are trademarks or registered trademarks of their respective companies.

For details on signal processor settings when driving speakers with the use of multiple power amplifiers, please refer to the web site below.

Yamaha Pro Audio global web site  
<http://www.yamahaproaudio.com/>

## Tri-Amp/Bi-Amp switch (IF3115 only)

Select the Tri-Amp mode (tri-amp drive) or the Bi-Amp mode (bi-amp drive).

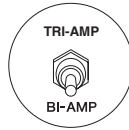

### CAUTION

Do not change the Tri-amp/Bi-amp setting while the speaker is in use.

## Bi-Amp/Passive switch (IH2000 only)

Select the Bi-Amp mode (bi-amp drive) or the Passive mode (full-range drive).

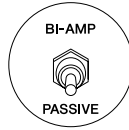

### CAUTION

Do not change the Bi-amp/Passive setting while the speaker is in use.

## Neutrik Speakon plug wiring

Connect the plugs as shown below.

### CAUTION

Be sure to use proper speaker cable – not shielded instrument or line cable – for all speaker connections.

**NOTE** The Speakon jack and barrier strip terminals are connected in parallel.

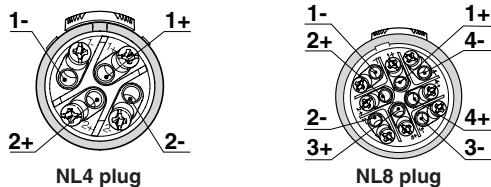

### IF3115

NEUTRIK plug	Tri-Amp (NL8 plug only)	Bi-Amp (NL8 plug/NL4 plug)
1+	LF+	LF+
1-	LF-	LF-
2+	MF+	MF/HF+
2-	MF-	MF/HF-
3+	HF+	
3-	HF-	
4+		
4-		

### IH2000

Neutrik NL4 plug	Bi-Amp	Passive
1+	MF+	+
1-	MF-	-
2+	HF+	
2-	HF-	

### IL1115

Neutrik NL4 plug	
1+	+
1-	-
2+	
2-	

## Suspended Installation

### CAUTION

- The strength of the suspension points on the speaker is **60 kg** per point (maximum).
- Before doing any installation or construction work, consult with an installation expert.
- When choosing the installation location, suspension wire and mounting hardware, make sure all are strong enough to support the weight of the speaker.
- Some fittings may deteriorate over extended periods of time due to wear and or corrosion. For optimum safety, the installation should be checked thoroughly at regular intervals.

Yamaha cannot be held responsible for damage or injury caused by insufficient strength of the support structure or improper installation.

## Using eye bolts for suspension

For optimum safety, make sure to carefully follow the precautions below.

### CAUTION

- Use only the supplied eye bolts.
- Use three or more eye bolts for suspended installations.
- Use the optional array frame if you intend to suspend a speaker from another suspended speaker.
- Install the eye bolts to multiple surfaces of the speaker, not just one surface.

## Eye bolt strength

Keep in mind that the strength of the eye bolt differs depending on the suspension angle of the speaker. Make sure that the load for each eye bolt is less than 740 kg when suspending at an angle of 0 degrees, and less than 185 kg at an angle of 45 degrees.

### CAUTION

When using the eye bolts, make sure that the suspension angle is within the range of 0 to 45 degrees, as shown at right.

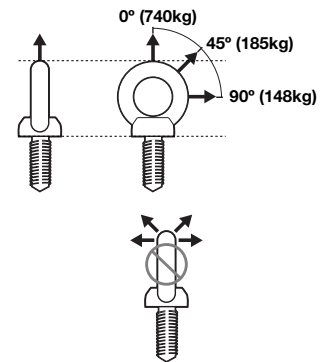

### CAUTION

Do not suspend the eye bolts as shown in the diagram at right.

## Rotatable horn (IF3115, IH2000 only)

1. Remove all fixing screws on the grille, and remove the grille from the speaker.
2. Remove all screws installed on the horn, pull out the horn from the speaker, rotate the horn 90 degrees, and re-install the horn to the speaker.

### CAUTION

Be careful when rotating the horn so that you do not accidentally cut the connection wires connected to the horn driver.

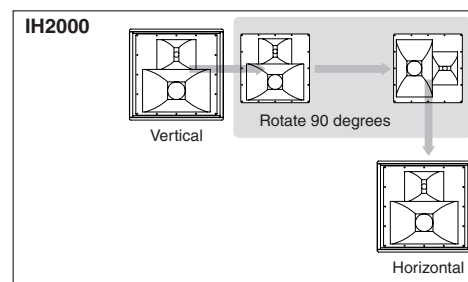
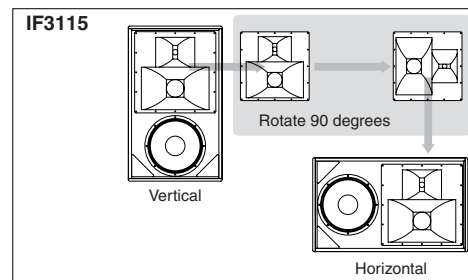

# Specifications

System Type	3way full-range speaker				3way full-range speaker				2way mid-high frequency speaker			2way mid-high frequency speaker			Low frequency speaker		
Model	IF3115/64(W)				IF3115/95(W)				IH2000/64(W)			IH2000/95(W)			IL1115(W)		
Specifications/Drive Mode	LF	Bi-amp		Tri-amp		LF	Bi-amp		Tri-amp		Passive			Bi-amp			—
		MF/HF	MF	HF	MF/HF		MF	HF	MF/HF	MF	HF	MF/HF	MF	HF			
Frequency Range (-10dB) (4π) <sup>*1</sup>	45 Hz-20k Hz (Tri-amp mode)								200 Hz-20k Hz (Bi-amp mode)						45 Hz-2.5k Hz		
Frequency Range (±3dB) (4π) <sup>*1</sup>	70 Hz-20k Hz (Tri-amp mode)								250 Hz-20k Hz (Bi-amp mode)						70 Hz-2k Hz		
Nominal Coverage(H x V, -6dB)	60° x 40°, can be rotated to 40° x 60°				90° x 50°, can be rotated to 50° x 90°				60° x 40°, can be rotated to 40° x 60°			90° x 50°, can be rotated to 50° x 90°			n/a		
Power Rating	700W (AES)	125W <sup>*2</sup>	125W (AES)	110W (AES)	700W (AES)	125W <sup>*2</sup>	125W (AES)	110W (AES)	125W <sup>*2</sup>	125W (AES)	110W (AES)	125W <sup>*2</sup>	125W (AES)	110W (AES)	700 W(AES)		
Nominal Impedance	8 ohms								8 ohms						8 ohms		
Sensitivity(1W@1m)	97dB SPL	106dB SPL	106dB SPL	110dB SPL	97dB SPL	106dB SPL	106dB SPL	108dB SPL	106dB SPL	106dB SPL	110dB SPL	106dB SPL	106dB SPL	108dB SPL	97dB SPL		
Calculated Peak SPL	131dB SPL	133dB SPL	133dB SPL	136dB SPL	131dB SPL	133dB SPL	133dB SPL	134dB SPL	133dB SPL	133dB SPL	136dB SPL	133dB SPL	133dB SPL	134dB SPL	131dB SPL		
Calculated Continuous SPL	125dB SPL	127dB SPL	127dB SPL	130dB SPL	125dB SPL	127dB SPL	127dB SPL	128dB SPL	127dB SPL	127dB SPL	130dB SPL	127dB SPL	127dB SPL	128dB SPL	125dB SPL		
<b>Components</b>																	
LF	15" (38cm) Woofer, 4" (100mm) Voice Coil								n/a						15" (38cm) Woofer, 4" (100mm) Voice Coil		
MF	Rotatable Constant Directivity Horn, 8" (20cm) Driver, 2" (50mm) Voice Coil								Rotatable Constant Directivity Horn, 8" (20cm) Driver, 2" (50mm) Voice Coil						n/a		
HF	Rotatable Constant Directivity Horn, 1.4" (36mm) exit, 3" (76mm) Voice Coil Compression Driver								Rotatable Constant Directivity Horn, 1.4" (36mm) exit, 3" (76mm) Voice Coil Compression Driver						n/a		
<b>Enclosure</b>																	
Dimensions (W x H x D)	610 x 1,006 x 600 mm ( 24.0 x 39.6 x 23.6 in)								610 x 591 x 600 mm (24.0 x 23.3 x 23.6 in)						610 x 591 x 600 mm (24.0 x 23.3 x 23.6 in)		
Weight	64kg (140lbs)								33kg (72lbs)						38kg (84lbs)		
Shape	30° Trapezoidal								30° Trapezoidal						30° Trapezoidal		
Material	3/4" (19mm), 13-ply Finnish Birch(Baffle, Partition) 5/8" (16mm), 11-ply Finnish Birch								3/4" (19mm), 13-ply Finnish Birch (Baffle) 5/8" (16mm), 11-ply Finnish Birch						3/4" (19mm), 13-ply Finnish Birch (Baffle) 5/8" (16mm), 11-ply Finnish Birch		
Finish	Textured Black (Textured White)								Textured Black (Textured White)						Textured Black (Textured White)		
Grill	16 gauge powder coated perforated steel grilles, backed with acoustically transparent reticulated foam								16 gauge powder coated perforated steel grilles, backed with acoustically transparent reticulated foam						16 gauge powder coated perforated steel grilles, backed with acoustically transparent reticulated foam		
Connectors	1x Neutric NL8, 1x Neutric NL4 and barrier strip, wired in parallel								1x Neutric NL4 and barrier strip, wired in parallel						1x Neutric NL4 and barrier strip, wired in parallel		
Flying Hardware	13x M10 for shoulder eyebolts								15x M10 for shoulder eyebolts and U-bracket						15x M10 for shoulder eyebolts and U-bracket		
Pole Mounts	n/a				n/a				n/a			n/a			n/a		
Handle	Four				Four				Two			Two			Two		
<b>Optional Accessory</b>																	
U-bracket	n/a				n/a				UB2000(W)			UB2000(W)			UB2000(W)		
Array Frame	HAF2-3115(W), HAF3-3115(W), HAF3-S18(W), VAF2-3115(W)								HAF2-3115(W), HAF3-3115(W), HAF3-S18(W), VAF2-3115(W)						HAF2-3115(W), HAF3-3115(W), HAF3-S18(W), VAF2-3115(W)		
<b>3rd party accessory</b>																	
OmniMount (US)	n/a								n/a						n/a		
Multimount (US, Allen Products)	n/a								n/a						n/a		
Powerdrive (UK)	n/a								n/a						n/a		
OHASHI (Japan)	n/a								n/a						n/a		

\* 1: With recommended YAMAHA DSP configuration.

\* 2: 2 hrs. IEC noise.

\* Specifications and descriptions in this owner's manual are for information purposes only. Yamaha Corp. reserves the right to change or modify products or specifications at any time without prior notice. Since specifications, equipment or options may not be the same in every locale, please check with your Yamaha dealer.

\* Die technischen Daten und Beschreibungen in dieser Bedienungsanleitung dienen nur der Information. Yamaha Corp. behält sich das Recht vor, Produkte oder deren technische Daten jederzeit ohne vorherige Ankündigung zu verändern oder zu modifizieren. Da die technischen Daten, das Gerät selbst oder Sonderzubehör nicht in jedem Land gleich sind, setzen Sie sich im Zweifel bitte mit Ihrem Yamaha-Händler in Verbindung.

\* Les caractéristiques techniques et les descriptions du mode d'emploi ne sont données que pour information. Yamaha Corp. se réserve le droit de changer ou modifier les produits et leurs caractéristiques techniques à tout moment sans aucun avis. Du fait que les caractéristiques techniques, les équipements et les options peuvent différer d'un pays à l'autre, adressez-vous au distributeur Yamaha le plus proche.

\* Las especificaciones y descripciones de este manual del propietario tienen sólo el propósito de servir como información. Yamaha Corp. se reserva el derecho a efectuar cambios o modificaciones en los productos o especificaciones en cualquier momento sin previo aviso. Puesto que las especificaciones, equipos u opciones pueden no ser las mismas en todos los mercados, solicite información a su distribuidor Yamaha.

\*仕様および外觀は改良のため予告なく変更することがあります。

# Dimensions

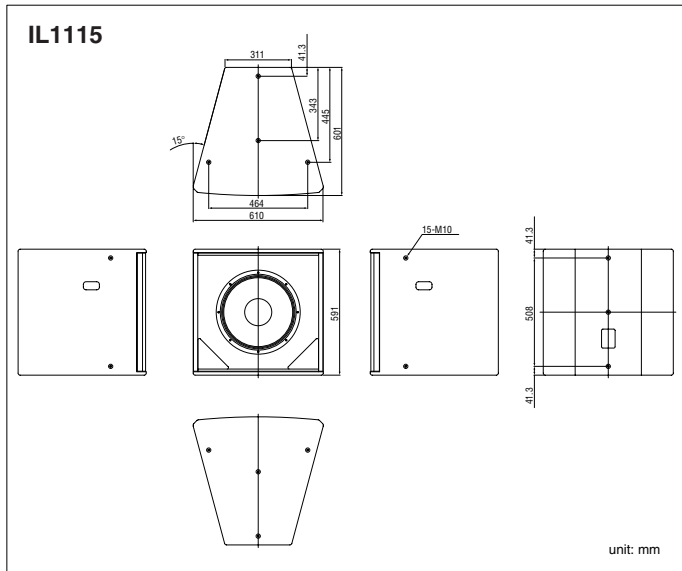
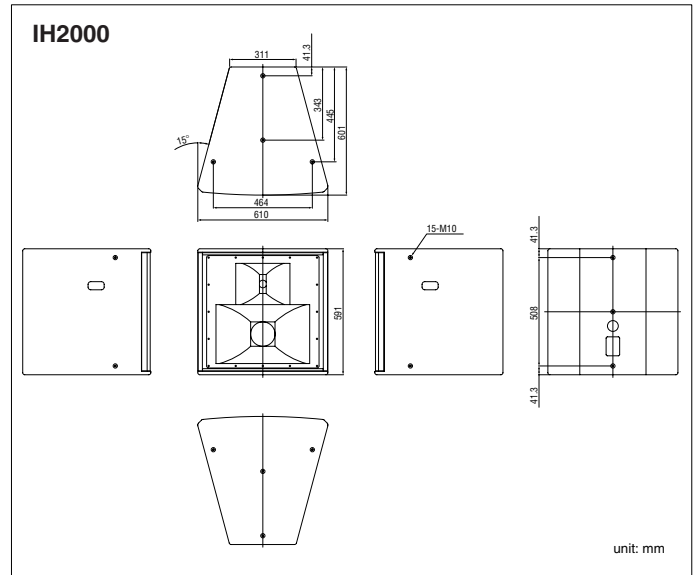
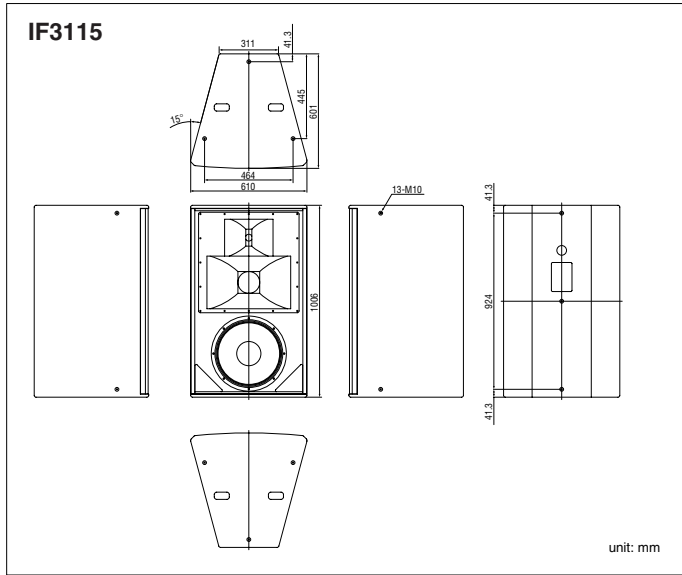

For details of products, please contact your nearest Yamaha representative or the authorized distributor listed below.

Pour plus de détails sur les produits, veuillez-vous adresser à Yamaha ou au distributeur le plus proche de vous figurant dans la liste suivante.

Die Einzelheiten zu Produkten sind bei Ihrer unten aufgeführten Niederlassung und bei Yamaha Vertragshändlern in den jeweiligen Bestimmungsländern erhältlich.

Para detalles sobre productos, contacte su tienda Yamaha más cercana o el distribuidor autorizado que se lista debajo.

## NORTH AMERICA

### CANADA

**Yamaha Canada Music Ltd.**  
135 Milner Avenue, Scarborough, Ontario,  
M1S 3R1, Canada  
Tel: 416-298-1311

### U.S.A.

**Yamaha Corporation of America**  
6600 Orangethorpe Ave., Buena Park, Calif. 90620,  
U.S.A.  
Tel: 714-522-9011

## CENTRAL & SOUTH AMERICA

### MEXICO

**Yamaha de México S.A. de C.V.**  
Calz. Javier Rojo Gómez #1149,  
Col. Guadalupe del Moral  
C.P. 09300, México, D.F., México  
Tel: 55-5804-0600

### BRAZIL

**Yamaha Musical do Brasil Ltda.**  
Rua Joaquim Floriano, 913 - 4º andar, Itaim Bibi,  
CEP 04534-013 Sao Paulo, SP. BRAZIL  
Tel: 011-3704-1377

### ARGENTINA

**Yamaha Music Latin America, S.A.**  
**Sucursal de Argentina**  
Olga Cossetini 1553, Piso 4 Norte  
Madero Este-C1107CEK  
Buenos Aires, Argentina  
Tel: 011-4119-7000

### PANAMA AND OTHER LATIN AMERICAN COUNTRIES/ CARIBBEAN COUNTRIES

**Yamaha Music Latin America, S.A.**  
Torre Banco General, Piso 7, Urbanización Marbella,  
Calle 47 y Aquilino de la Guardia,  
Ciudad de Panamá, Panamá  
Tel: +507-269-5311

## EUROPE

### THE UNITED KINGDOM

**Yamaha Music U.K. Ltd.**  
Sherbourne Drive, Tilbrook, Milton Keynes,  
MK7 8BL, England  
Tel: 01908-366700

### GERMANY

**Yamaha Music Central Europe GmbH**  
Siemensstraße 22-34, 25462 Rellingen, Germany  
Tel: 04101-3030

### SWITZERLAND/LIECHTENSTEIN

**Yamaha Music Central Europe GmbH,**  
**Branch Switzerland**  
Seefeldstrasse 94, 8008 Zürich, Switzerland  
Tel: 01-383 3990

### AUSTRIA

**Yamaha Music Central Europe GmbH,**  
**Branch Austria**  
Schleiergasse 20, A-1100 Wien, Austria  
Tel: 01-60203900

### CZECH REPUBLIC/SLOVAKIA/ HUNGARY/SLOVENIA

**Yamaha Music Central Europe GmbH,**  
**Branch Austria, CEE Department**  
Schleiergasse 20, A-1100 Wien, Austria  
Tel: 01-602039025

### HEAD OFFICE

**Yamaha Corporation, Pro Audio & Digital Musical Instrument Division**  
Nakazawa-cho 10-1, Naka-ku, Hamamatsu, Japan 430-8650  
Tel: +81-53-460-2441

### POLAND

**Yamaha Music Central Europe GmbH**  
**Sp.z o.o. Oddział w Polsce**  
ul. 17 Stycznia 56, PL-02-146 Warszawa, Poland  
Tel: 022-868-07-57

### THE NETHERLANDS/ BELGIUM/LUXEMBOURG

**Yamaha Music Central Europe GmbH,**  
**Branch Benelux**  
Clarissenhof 5-b, 4133 AB Vianen, The Netherlands  
Tel: 0347-358 040

### FRANCE

**Yamaha Musique France**  
BP 70-77312 Marne-la-Vallée Cedex 2, France  
Tel: 01-64-61-4000

### ITALY

**Yamaha Musica Italia S.P.A.**  
**Combo Division**  
Viale Italia 88, 20020 Lainate (Milano), Italy  
Tel: 02-935-771

### SPAIN/PORTUGAL

**Yamaha Música Ibérica, S.A.**  
Ctra. de la Coruna km. 17, 200, 28230  
Las Rozas (Madrid), Spain  
Tel: 91-639-8888

### SWEDEN

**Yamaha Scandinavia AB**  
J. A. Wettergrens Gata 1, Box 30053  
S-400 43 Göteborg, Sweden  
Tel: 031 89 34 00

### DENMARK

**YS Copenhagen Liaison Office**  
Generatorvej 6A, DK-2730 Herlev, Denmark  
Tel: 44 92 49 00

### NORWAY

**Norsk filial av Yamaha Scandinavia AB**  
Grini Næringspark 1, N-1345 Østerås, Norway  
Tel: 67 16 77 70

### RUSSIA

**Yamaha Music (Russia)**  
Office 4015, entrance 2, 21/5 Kuznetskii  
Most street, Moscow, 107996, Russia  
Tel: 495 626 0660

### OTHER EUROPEAN COUNTRIES

**Yamaha Music Central Europe GmbH**  
Siemensstraße 22-34, 25462 Rellingen, Germany  
Tel: +49-4101-3030

## AFRICA

**Yamaha Corporation,**  
**Asia-Pacific Music Marketing Group**  
Nakazawa-cho 10-1, Naka-ku, Hamamatsu,  
Japan 430-8650  
Tel: +81-53-460-2313

## MIDDLE EAST

### TURKEY/CYPRUS

**Yamaha Music Central Europe GmbH**  
Siemensstraße 22-34, 25462 Rellingen, Germany  
Tel: 04101-3030

### OTHER COUNTRIES

**Yamaha Music Gulf FZE**  
LOB 16-513, P.O.Box 17328, Jubel Ali,  
Dubai, United Arab Emirates  
Tel: +971-4-881-5868

## ASIA

### THE PEOPLE'S REPUBLIC OF CHINA

**Yamaha Music & Electronics (China) Co.,Ltd.**  
25/F., United Plaza, 1468 Nanjing Road (West),  
Jingan, Shanghai, China  
Tel: 021-6247-2211

### INDONESIA

**PT. Yamaha Music Indonesia (Distributor)**  
**PT. Nusantik**  
Gedung Yamaha Music Center, Jalan Jend. Gatot  
Subroto Kav. 4, Jakarta 12930, Indonesia  
Tel: 21-520-2577

### KOREA

**Yamaha Music Korea Ltd.**  
8F, 9F, Dongsung Bldg. 158-9 Samsung-Dong,  
Kangnam-Gu, Seoul, Korea  
Tel: 080-004-0022

### MALAYSIA

**Yamaha Music Malaysia, Sdn., Bhd.**  
Lot 8, Jalan Perbandaran, 47301 Kelana Jaya,  
Petaling Jaya, Selangor, Malaysia  
Tel: 3-78030900

### SINGAPORE

**Yamaha Music Asia Pte., Ltd.**  
#03-11 A-Z Building  
140 Paya Lebar Road, Singapore 409015  
Tel: 747-4374

### TAIWAN

**Yamaha KHS Music Co., Ltd.**  
3F, #6, Sec.2, Nan Jing E. Rd. Taipei.  
Taiwan 104, R.O.C.  
Tel: 02-2511-8688

### THAILAND

**Siam Music Yamaha Co., Ltd.**  
4, 6, 15 and 16<sup>th</sup> floor, Siam Motors Building,  
891/1 Rama 1 Road, Wangmai,  
Pathumwan, Bangkok 10330, Thailand  
Tel: 02-215-2626

### OTHER ASIAN COUNTRIES

**Yamaha Corporation,**  
**Asia-Pacific Music Marketing Group**  
Nakazawa-cho 10-1, Naka-ku, Hamamatsu,  
Japan 430-8650  
Tel: +81-53-460-2317

## OCEANIA

### AUSTRALIA

**Yamaha Music Australia Pty. Ltd.**  
Level 1, 99 Queensbridge Street, Southbank,  
Victoria 3006, Australia  
Tel: 3-9693-5111

### COUNTRIES AND TRUST TERRITORIES IN PACIFIC OCEAN

**Yamaha Corporation,**  
**Asia-Pacific Music Marketing Group**  
Nakazawa-cho 10-1, Naka-ku, Hamamatsu,  
Japan 430-8650  
Tel: +81-53-460-2313

Yamaha Pro Audio global web site  
<http://www.yamahaproaudio.com/>  
Yamaha Manual Library  
<http://www.yamaha.co.jp/manual/>

U.R.G., Pro Audio & Digital Musical Instrument Division, Yamaha Corporation  
© 2005 Yamaha Corporation  
WJ54090 MW-04E0